

**SCIENTIFIC
WORKS**

Katarzyna Kaczorek-Chrobak

FIRE PROPERTIES OF ELECTRIC CABLES USED IN BUILDINGS



Instytut Techniki Budowlanej

Katarzyna Kaczorek-Chrobak

FIRE PROPERTIES OF ELECTRIC CABLES USED IN BUILDINGS

PUBLICATIONS OF THE INSTYTUT TECHNIKI BUDOWLANEJ

include, among others, the following works:

SCIENTIFIC WORKS – MONOGRAPHS, DISSERTATIONS, STUDIES

INSTRUCTIONS, GUIDELINES, GUIDES

**TECHNICAL REQUIREMENTS FOR EXECUTION AND ACCEPTANCE
OF CONSTRUCTION WORKS**

DESIGNING ACCORDING TO EUROCODES

PROGRAMME BOARD OF ITB PUBLICATIONS

Chairperson	PhD Eng. Jadwiga Fangrat, Prof. of ITB
Secretary	Eng. Marek Gębarzewski
Board Members	Prof. PhD Eng. Lech Czarnecki, Dr h.c. MSc Eng. Jan Sieczkowski PhD Eng. Jacek Szer, Prof. of PŁ PhD Eng. Wojciech Węgrzyński, Prof. of ITB PhD Eng. Michał Wójtowicz

**SCIENTIFIC
WORKS**
Monographs

Katarzyna Kaczorek-Chrobak

**FIRE PROPERTIES
OF ELECTRIC CABLES
USED IN BUILDINGS**



Instytut Techniki Budowlanej

Warsaw 2023

EDITORIAL COMMITTEE

Editor-in-chief Prof. PhD Eng. LECH CZARNECKI, Dr h.c.
Deputy editors-in-chief Prof. PhD Eng. LESŁAW BRUNARSKI
PhD Eng. JADWIGA FANGRAT, Prof. of ITB
Secretary PhD MICHAŁ GAJOWNIK
Board Members PhD Eng. JACEK NURZYŃSKI, Prof. of ITB
MSc Eng. JAN SIECZKOWSKI
PhD Eng. EWA SZEWCZAK
PhD Eng. SEBASTIAN WALL

Reviewers

PhD Eng. ANDRZEJ PLICHTA, Prof. of PW
Senior Brigadier Prof. PhD MARZENA PÓŁKA

Editor

PhD MICHAŁ GAJOWNIK

© Copyright by Instytut Techniki Budowlanej
Warsaw 2023

*Four hundred seventy-fifth release of
"ITB Scientific Works"*

ISBN 978-83-249-8660-6; 978-83-249-8661-3 (PDF)

The Publisher and the Authors have made every effort to ensure that the published information comes from reliable sources. The Publisher shall not bear liability or incur any obligations as a result of using the contents of this publication by any user. In particular, they shall not bear liability to readers and/or any third party for any direct and indirect losses, expenses as well as direct or indirect damage incurred, including the loss of profit and other financial benefits, which may have arisen or may have been directly or indirectly connected with the published contents, including any potential errors or omissions in the published materials.



Instytut Techniki Budowlanej

Scientific Publications Department

02-656 Warsaw, ul. Ksawerów 21, phone: +48 22 843 35 19
phone: +48 22 56 64 208, e-mail: wydawnictwa@itb.pl www.itb.pl

Contents

<i>Summary</i>	7
From the Author.....	11
Terms and definitions.....	13
List of abbreviations and Greek characters.....	15
1. Introduction.....	17
2. Role and functions of electric cables in buildings.....	23
3. Current state of knowledge on fire behaviour of electric cables.....	27
3.1. Electrical installations and cables.....	27
3.2. Fire spread in buildings as a result of cable fires.....	29
3.3. Cable fire testing.....	30
3.4. Fire tests in microgravity.....	32
3.5. Numerical simulations of cable fires.....	34
3.6. Fire effluent toxicity.....	37
4. Scientific problem.....	43
5. Constructional and material parameters of studied cables.....	47
6. Experimental methods.....	59
6.1. Large-scale cable experiments.....	59
6.2. Small-scale cable experiments.....	61
7. Fire properties of studied cables.....	69
8. Analysis of the relationship between constructional-material parameters and the fire properties of electric cables.....	79
8.1. Tests results and discussion for a large number of cables of various construction.....	79
8.2. Statistical analysis.....	111
9. Discussion on the current cable parameter χ	115
10. Author's concept of new cable parameter.....	119
11. Application of Quintiere's theory.....	127
12. Conclusions.....	133
References.....	135

FIRE PROPERTIES OF ELECTRIC CABLES USED IN BUILDINGS

Summary

A significant number of cables of different materials and construction is used extensively in building objects increasing their fire load and, therefore, strongly influencing safety in the case of fire. Electric cables and electrical installations constructed from them, despite being important elements of fire safety, are not considered in the general analysis of the fire safety of buildings and are usually not assessed as potential fire risks. One of the tasks in the field of counteracting fire hazards in buildings should be to reduce the risk of fires caused by short circuits in electrical installations. In the event of fire, the process of fire propagation involving electric cables should be considered, which, due to the way cables are installed in buildings, can transfer fire over long distances from the origin of the fire and across storeys through installation shafts.

The scientific problem of the doctoral dissertation is to determine the impact of significant constructional and material parameters of electric cables on their fire properties by establishing the qualitative, and possibly also quantitative, relationships between these parameters.

The aim of the presented work was to investigate the effect of material and constructional parameters on the fire properties of electrical cables, such as heat release, smoke generation, range of flame spread and amount of toxic fire effluents under various ventilation conditions. To the best of the author's knowledge, such systematic research has not been published so far. The presented study is original and fills the scientific gap regarding the constructional and material parameters of electric wires and cables, which influence their fire properties.

In order to investigate the relationship between the constructional-material parameters of cables and their fire properties, eighty-three cables (eighty-nine cable samples) were examined by means of a standard experimental method. The selection of cable samples included the presence of one distinctive parameter. The conclusions drawn from the experiments were as follows: (1) construction, the number of conductors and the presence of armour or concentric metallic conductors improve fire properties by forming a barrier against flame penetration through the cable; (2) the use of copper conductors resulted in decreasing fire parameters compared to cables with aluminium conductors (maximum average heat release rate parameter al-

most four times lower for copper cables); (3) construction materials based on plasticised poly(vinyl chloride) significantly reduce the fire properties of cables compared to halogen-free materials (maximum average heat release rate parameter more than 17 times higher for fully halogenated cables), which is due to the decomposition process of the material; (4) no clear relationship between the fire parameters and cable parameter χ was found. The χ parameter was developed to improve the monotonicity of the reaction to the fire test results obtained and has been used in the selection of cable samples for testing within the same cable family so far.

As the investigation showed a significant impact of the number of metallic barriers (conductors) on flame penetration into the inner layers of electric cables and the volume of non-metallic materials on the fire properties of cables, a parameter related to the volume of effective non-combustible content Ω was proposed. The new Ω parameter depends on the non-metallic non-combustible components volume to non-metallic combustible components volume ratio and the effective area of heat transfer within the cable. Increasing Spearman's correlation factors (close to -1) were obtained for total heat release rate and total smoke generation parameters as a function of the Ω parameter rather than the χ parameter.

In order to examine the amount of fire/combustion gases under ventilation-controlled fires, a simple poly(vinyl chloride)-based copper electric wire widely used in buildings was studied by means of a Steady State Tube Furnace. A reference pure polymer unplasticised poly(vinyl chloride) and additionally pure low-density polyethylene were also tested. Decreasing carbon dioxide yields at different ventilation conditions for the poly(vinyl chloride) based copper electric wire were obtained in comparison to three times higher yields for pure poly(vinyl chloride) and two times for low-density polyethylene than those received for the tested wire at the same ventilation conditions, which confirms the insignificant contribution of the hyperventilation effect to humans during a cable fire. To the contrary, four times higher values of toxic carbon monoxide yields were obtained for the tested wire rather than for the reference polymer and pure low-density polyethylene. The maximum value of carbon monoxide yield (0.57 g/g) was obtained in the case of 5 l/min of primary airflow, which decreased with increasing ventilation. The measured yields of hydrocarbons were similar to the reference values except for the equivalence ratio $\phi = 0.27$. The corrosive and toxic hydrochloric acid occurring in fire effluents from the studied wire was independent of the ventilation conditions tested. The reaction between copper and the hydrochloric acid compound, inorganic fillers, and hydrochloric acid decreased the hydrochloric acid content in fire effluents.

Analysis using Quintiere's theory showed that the cone calorimeter method can be used in numerical modelling of the cable burning process, and its use can significantly facilitate and reduce the number of cable fire tests, without adversely affecting the final results.

Summarising, the analysis of the impact of cable construction is an important element from the point of view of the fire safety of buildings. In the course of the study, it was found that factors such as the shape, number and material used for conductor formulation, as well as the types of materials from which the non-metallic elements of the cables are made, and the presence of armour or concentric conductors significantly influence the fire properties of cables, such as heat release, smoke generation, range of fire spread and fire effluent toxicity, largely reducing the fire properties of cables. The experiments enabled the development of a new cable parameter Ω , which is a better predictive indicator of cable flammability than the standard and commonly used parameter χ . In addition, it was found that it is possible to replace large geometric scale fire tests with a simpler cone calorimeter method by applying Quintiere's theory of electric cables.

FROM THE AUTHOR

Fire safety is multidisciplinary in nature and combines scientific disciplines such as physics, chemistry, mechanics as well as modelling and numerical simulation. The increasing use of electrically powered equipment is driving the demand for sophisticated designs and materials used to construct the electrical cables that power these devices. Consequently, under fire conditions, cables contribute a significant fire load and are involved in the spread of fire throughout a building. This monograph is based on the author's doctoral dissertation [5], in English, considering the reviewers' comments and questions raised during the public defense.

The issues addressed therein are primarily concerned with the proper selection of electrical cables in terms of their fire performance. A meticulous analysis of the influence of design and material parameters on the behaviour of electrical cables under fire conditions was carried out on a large number of electrical cables commonly manufactured and used in Europe. A novel concept of an empirical parameter Ω , related to the effective volume of non-metallic elements, the volume of combustible non-metallic elements of cables and the effective heat transfer surface area, was also proposed.

I would like to express my sincere gratitude to dr hab. inż. Jadwiga Fangrat, Professor at Building Research Institute, for valuable advice given during the preparation of the dissertation and for her kindness and understanding, as well as to the reviewers of the monography – Senior Brigadier dr hab. Marzena Półka, Professor at the Main School of Fire Service, and dr. hab. Andrzej Plichta, Professor at the Warsaw University of Technology, for their insightful reviews, which undoubtedly contributed to raising the substantive quality of the monograph. I would also like to express my gratitude to the Management of the Building Research Institute for their support in conducting the fire testing of electrical cables, as well as to the team of the Building Research Institute Library for their assistance in completing the scientific literature. I would like to thank the management and my colleagues from the Fire Research Department for their kind support of my work and inspiring discussions.

I also thank the team of the Scientific Publications Department of the Building Research Institute for their efforts put into the preparation of this monography.

Katarzyna Kaczorek-Chrobak

Terms and definitions

Cable family – a specific range of products of the same general construction, materials and voltage rating and varying only in conductor size and number of cores [1].

Cable sample – sample of a cable of a particular group exhibiting the studied cable parameters (author's definition).

Combustion – exothermic reaction of a substance with an oxidising agent, generally emitting fire effluent accompanied by flames and/or glowing [2].

Communication cable – assembly of suitably insulated non-circular conductors or twisted pairs of insulated conductors fabricated to meet transmission, mechanical and environmental requirements, and suitable for allowing the conveyance of information between two points with the minimum of radiation [3].

Control cable – assembly comprising insulated conductors, together with any coverings and protective layers, used for the transmission of control, measuring and indication signals in electric installations [3].

Electric cables – all power, control and communication cables, including optical fibre cables, which are intended for supplying electrical energy or signals [3].

Fire behaviour – change in or maintenance of the physical and/or chemical properties of an item and/or structure exposed to fire [2].

Fire performance – response of a material, product or assembly in a fire [2].

Fire property – material/product properties related to the processes taking place at high (fire) temperatures (author's definition).

Flashover – transition to a state of total surface involvement in a fire of combustible materials within an enclosure [2].

Fractional Effective Dose (FED) – ratio of the exposure dose for an asphyxiant to that exposure dose of the asphyxiant expected to produce a specified effect on an exposed subject of average susceptibility [2].

Maximum heat release rate (peakHRR) – maximum thermal energy released per unit of time by an item during combustion under specified conditions, excluding contribution from the ignition source, from test start until test end (1200 s) as determined in EN 50399; mean value from 30 s [4].

Maximum smoke production rate (peakSPR) – maximum value of smoke generated from specimen per unit of time over 1200 s of EN 50399 test duration; mean value from 60 s [4].

Optical fibre cable – assembly comprising one or more optical fibres or fibre bundles inside a common covering designed to protect them against mechanical stresses and other environmental influences while retaining the transmission quality of the fibres [3].

Power cable – assembly comprising one or more insulated conductor(s), together with any covering and protective layers, used for the transmission or supply of electrical energy [3].

Reaction to fire – response of a test specimen exposed to fire under specified conditions during a fire test [2].

Test specimen – item subjected to assessment or measurement [2].

Total heat release (THR_{1200s}) – integrated value of the heat release rate generated from the specimen, excluding contribution from the ignition source, from test start until test end (1200 s) as determined in EN 50399 [4].

Total smoke production (TSP_{1200s}) – integrated value of smoke production rate over 1200 s of EN 50399 test duration [4].

Vertical flame spread (FS) – damage length of the specimen, as measured in EN 50399 [4].

List of abbreviations and Greek characters

Abbreviations

a and b	– slope and intercept of the interactive curve of CO and CO ₂ respectively, which depict the rising toxicity of CO and CO ₂ concentration increases [-]
A	– acidosis factor [-]
Abs	– absorbance [-]
AEP	– available energy parameter [MJ/m ²]
ATH	– aluminium trihydrate
ATR-FTIR	– Attenuated Total Reflectance – Fourier Transform Infrared spectrometry
c	– heat capacity [kJ/(kg×K)]
CHF	– critical heat flux [kW/m ²]
[CO]	– carbon monoxide concentration [%]
[CO ₂]	– carbon dioxide concentration [%]
d_{cable}	– diameter of cable [mm]
d_{met}	– diameter of conductor [mm]
EHC	– effective heat of combustion [MJ/kg]
EPDM	– ethylene/propylene diene monomer
EPU	– polyurethane elastomer
FEC	– Fractional Effective Concentration [-]
FED	– Fractional Effective Dose [-]
FS	– range of flame spread [m]
h	– length of cable [m]
[HC]	– hydrocarbon (saturated, unsaturated and aromatic) concentration [%]
[HCl]	– hydrogen chloride concentration [%]
HRP	– heat release parameter [-]
HRR	– heat release rate [kW]
IC ₅₀	– concentration of irritant gases [%] or [ppm]
k	– thermal conductivity [W/(m×K)]
k_{pc}	– thermal inertia factor [kW ² /(m ⁴ ×K ² ×s)]
LC ₅₀	– lethal concentration [%] or [ppm]
LDPE	– low-density polyethylene

LS0H	- Low Smoke Zero Halogen material
m	- TGA specimen mass [mg]
n	- number of conductors [-]
[O ₂]	- oxygen concentration [%]
PE	- polyethylene
peakHRR _{av}	- maximum average heat release rate [kW]
peakHRR _{pua}	- maximum heat release rate per unit area [kW/m ²]
peakSPR _{av}	- maximum average smoke production rate [m ² /s]
PVC	- poly(vinyl chloride)
q_e^n	- external incident heat flux at surface [kW/m ²]
$r_{x,y}$	- Spearman's correlation factor [-]
RSR	- rate of smoke release [(m ² /s)/m ²]
SPR	- smoke production rate [m ² /s]
TGA	- Thermogravimetric Analysis
THR	- total heat release [MJ]
T_0	- ambient temperature [°C]
t_{ig}	- time to ignition [s]
T_{ig}	- ignition temperature (or temperature to ignition) [°C]
TRP	- thermal response parameter [(kW/m ²)×s ^{1/2}]
TSP	- total smoke production [m ²]
v_{av}	- average speed of flame spread [m/s]
V_{CO_2}	- multiplication factor for CO ₂ driven hyperventilation [-]
$V_{combust}$	- non-metallic volume of cable per 1 m of ladder according to EN 50399 [l/m of cable]
XLPE	- cross-linked polyethylene
XLPO	- cross-linked polyolefin
z	- surface ratio [-]
ZnB	- zinc borate

Greek characters

Δm	- absolute mass loss of TGA specimen [-]
ϕ	- equivalence ratio [-]
ρ	- density of material [kg/m ³]
χ	- cable parameter [-]
ω	- non-metallic non-combustible components volume to non-metallic combustible components volume ratio [-]
Ω	- volume of effective non-combustible content parameter [l/m of cable]

1. INTRODUCTION

World statistics indicate that 37.3% of fires in 2017 occurred in residential buildings. In the same year, the highest number of fire deaths occurred in the following countries: Russia, Belarus, Latvia, Ukraine, Lithuania and Estonia, and this trend does not seem to be shifting. In Poland, 475 fire victims were registered in 2017 [6]. In 2019, about 153,500 fires were recorded in Poland, including almost 38,000 in public and residential buildings, factories and warehouses (Fig. 1), where 507 deaths occurred [7].

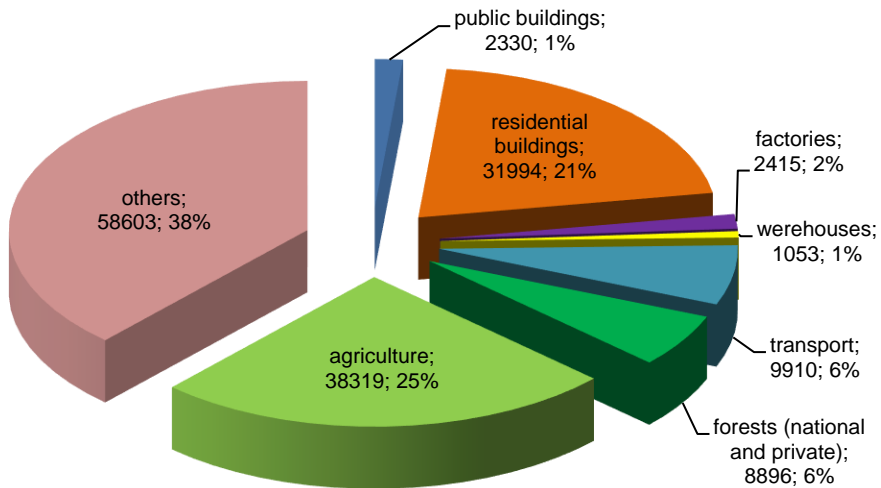

Fig. 1. Number of fires in Poland in 2019 in terms of type of object [7]

Any fire that breaks out in a building is of an exceptional, destructive nature [8]. When the fire occurs, the following changes in the environment take place:

- thermal conditions,
- pressure,
- chemical composition of air in the fire zone (hyperventilation and toxic products generation),
- smoke obscuration [9].

In accordance with the 'Technical conditions to be met by buildings and their location' [10], buildings are divided into appropriate fire resistance classes. Those classes are ordered from the highest (A) to the lowest (E). The fire threat to people class (ZL) refers to residential, multi-occupancy and public buildings. The choice of these classes depends on the size of the building, the number of floors and the number of people staying in the building at any one time.

Construction products are evaluated for their fire safety. These include mainly properties related to the fire resistance of buildings and the reaction to fire of the building materials used in the buildings.

The term "fire resistance" denotes the 'ability of an element of building construction, component or structure to fulfil, for a stated period of time, the required stability, fire integrity and/or thermal insulation and/or other expected duty in a standard fire resistance test', whereas the term "reaction to fire" refers to the 'response of a material under specified test conditions contributing to a fire to which it is exposed' [11].

Nowadays, fire protection is aimed at minimising the risk of a fire in order to protect life and property. The construction of high-rise buildings, skyscrapers and large space warehouses has led to new challenges in the field of fire safety, especially in the case of fire toxicity [12], whose indispensable foundations are chemical processes generally included in fire chemistry.

Some electrical products, such as insulated cables and installation pipes may, in practice, occupy large areas of building structures and their finishing materials, or may pass through firewalls. In such cases, electrical products exposed to an external fire should be assessed from the point of view of their contribution to the fire hazard, compared to the contribution of construction materials or of a structure without electrical installations.

In general, each fire is a serious environmental issue, but cable fires create additional damage to the environment, as 90% of wires and cables contain halogen due to technological (e.g. simple construction) and financial (low cost) purposes [13]. In the case of the fire behaviour of cables commonly used in buildings, a number of different cables divided into cable families have been examined [14, 15].

The risk of fire has to be considered for each electrical installation when designing the component circuit and device, and when selecting the material in order to reduce the probability of a fire, due to unpredictable or abnormal use, faulty operation, or damage. The main goal of fire protection is to prevent an ignition originating in the part supplied with electrical power, and when an ignition does occur, to restrict the fire

within the limits of the electrical equipment. In case the surfaces of electrical products are exposed to external fire, it is necessary to ensure that they do not contribute to further fire spread more than the construction materials and structures in their vicinity.

The fire hazard presented by electrical equipment depends on its properties, operational conditions and on the properties of its environment. This is why the fire hazard assessment procedure should specify the description of the product, and the conditions of its operation and its environment. These are all elements of the process of evaluation of construction products in terms of fire safety according to the CEN procedures based on [16] (Fig. 2).

The first stage – fire scenario – is the most important, because it answers the following question: what is the type of fire to be considered? The answer allows for the designing of a new experimental method or the use of an existing one to test the product or element.



Fig. 2. Process of evaluation of construction products in terms of fire safety according to CEN procedures based on [16, 17]

The second stage – criteria – defines the evaluation criteria (limits) of fire safety measures in order to compare the behaviour of different products under the defined conditions of the chosen fire scenario in stage (1). Then, the evaluation limits can be established in terms of: (a) Health and life safety, and (b) Loss of property. Indirect methods are also very useful at this stage.

The third stage is the interpretation of the test results obtained during the experimental and indirect methods of analysis performed in stage (2), leading to the fourth stage (4), which is the evaluation through an assigned class (e.g. euro class).

In the cited doctoral dissertation [5] the properties of materials subjected to high (fire) temperatures are referred to as “fire properties” which is often used in scientific articles and monographs [18, 19, 20, 21] by analogies to commonly used terms “mechanical properties”, “chemical properties”, “physical properties”. On the other hand, the term “fire performance” is in use when addressing the cable fire behaviour in large-scale standard experiments [2, 16, 17, 22, 23, 24, 25]. In this monography the term “fire properties” is used in more general meaning than “fire performance”. This approach was based of the example of Hirschler, who stated [19] ‘The fire properties addressed include ignitability, ease of extinction (oxygen index), flame spread (small scale and intermediate scale), heat release, smoke obscuration, smoke toxicity, hydrogen chloride emission and decay, and performance in real-scale fires.’

In terms of fire chemistry, the basic fire scenarios are classified into various types: non-flaming/smouldering combustion, well-ventilated flaming fires and early/ventilation-controlled (vitiated) flaming fires (Tab. 1) [26, 27]. This evaluation is important in terms of the release of toxic combustion products from electric cables.

Smouldering/non-flaming fires involve slow thermal decomposition without flames. The thermal decomposition process may be induced by heat supplied externally or it may be self-sustaining. Products are very rich in inorganic acids, carbon monoxide (CO) and organic compounds, which are usually highly irritating to the respiratory tract [28, 29].

Table 1. Evaluation of standard fire types [30]

	Heat [kW m ⁻²]	Max temp. [°C]		Oxygen [%]		Equi- valence ratio ϕ	$\frac{V_{CO}}{V_{CO_2}}$	Combustion Efficiency [%]
		fuel	smoke	in	out			
Non-flaming								
1a. Self- -sustained smouldering	n.a.	450 to 800	25 to 85	20	0 to 20	-	0.1 to 1	50 to 90
1b. Oxidative, external radiation	-	300 to 600	-	20	20	< 1	-	-
1c. Anaerobic external radiation	-	100 to 500	-	0	0	>> 1	-	-

	Heat [kW m ⁻²]	Max temp. [°C]		Oxygen [%]		Equi- valence ratio ϕ	$\frac{V_{CO}}{V_{CO_2}}$	Combustion Efficiency [%]
		fuel	smoke	in	out			
Well-ventilated flaming								
2. Well- -ventilated flaming	0 to 60	350 to 650	50 to 500	~20	0 to 20	< 1	< 0.05	> 95
Under-ventilated flaming								
3a. Low ventilation room fire	0 to 30	300 to 600	50 to 500	15 to 20	5 to 10	> 1	0.2 to 0.4	70 to 80
3b. Post- -flashover	50 to 150	350 to 650	> 600	< 15	< 5	> 1	0.1 to 0.4	70 to 90

Well-ventilated flaming fires occur at the beginning of a fire, when there is plenty of air available. The equivalence ratio ϕ (1) [31, 32], which is used for the characterisation of ventilation conditions in terms of fire, is relatively low (less than 1) [33]. Typically, for well-ventilated fires, ϕ is less than 0.7 [31].

$$\phi = \frac{\text{actual fuel - to - air ratio}}{\text{stoichiometric fuel - to - air ratio}} \quad (1)$$

Under these conditions combustion is most efficient. The main products obtained during decomposition are carbon dioxide (CO₂), water and heat. The yield of smoke and toxic products initially tends to be low [28].

When the air supply is restricted compared to the fuel available for combustion, ventilation-controlled flaming fires occur. They may consist of pre-flashover fires in enclosed spaces or large post-flashover fires, where all surfaces are ignited in high temperature (often 450 – 1200°C) conflagrations in very large or ventilated spaces. Therefore, ventilation-controlled fires tend to be the worst for toxicity, because they produce large amounts of effluent containing high yields of toxic products, for instance: CO, CO₂, HCN, organic products, and a lot of smoke and inorganic acid gases [28].

The main cause of injury and death in fires is incapacitation resulting from exposure to fire effluents. In Poland, such a dataset is lacking. It has been mentioned, however, that statistically 60 – 80% of fire victims have been affected by fire effluents inhalation during a fire [34].

2. ROLE AND FUNCTIONS OF ELECTRIC CABLES IN BUILDINGS

The design, purpose and significant number of cables (amounting to a few hundred metres in a single room) installed as part of electrical installations in buildings, increases their fire load and may facilitate flame spread to other interior finishing elements, elevations etc. Their role in buildings is to supply electricity to the various devices inside and outside the facility. For aesthetic reasons, multiple electric cables connected to devices of various types and purposes are hidden flush-mounted in buildings, below raised floors, over suspended ceilings or inside poly(vinyl chloride) (PVC) cable channels and on cable trays (Fig. 3).

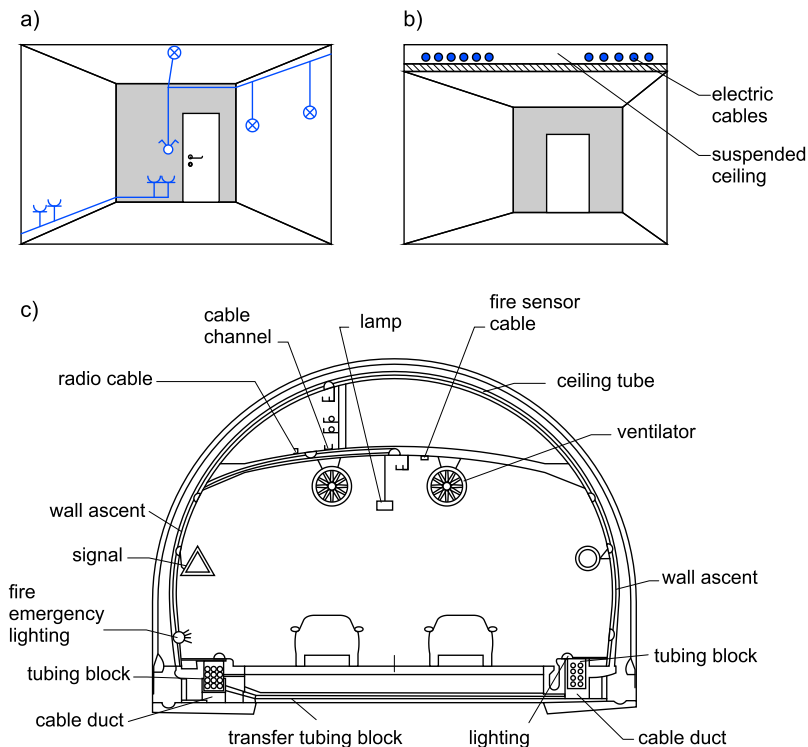

*Fig. 3. Schemes of cabling routes in different scenarios
a) residential building, b) corridor in the office building as part of escape route,
c) road tunnel [35]*

Based on the end-use application, cables can be divided into groups, as follows:

- 1) power,
- 2) communication, network,
- 3) flexible device connections,
- 4) control,
- 5) optical fibre cables.

The use of electric cables brought to the foreground the need to protect against electric shock, overload and short-circuit current, switching overvoltage, lightning and numerous heat effects [36], including fire.

Cables can be relatively easily self-ignited internally for a variety of reasons, including:

- 1) a short circuit in the installation due to the defective condition of fuses and other surge protectors and cable insulations, as well as the ageing of existing installations and their components,
- 2) an external burning source,
- 3) defective electric installation (Fig. 5),
- 4) improper use of electrical equipment (Fig. 4),
- 5) overheating of cable insulation over a longer distance due to the deterioration of cooling conditions,
- 6) overloading of the electrical system due to the flow of currents greater than the current carrying capacity of the wires or the rated current of electrical appliances and devices [36, 37].



Fig.4. Improper installed current switchgear



Fig. 5. Examples of the effect of improper use of electrical equipment

Building products like electrical cables and their installation ducts may cover an unexpectedly large surface inside buildings, often up to several hundreds of metres in a single room (Fig. 6) or thousands of metres in a single residential building, substantially increasing its overall fire load.



Fig. 6. Examples of cable routing in newly built and renovated residential buildings

There are different types of electrical installations inside a building, which can be divided by their application as follows:

- 1) power supply installations,
- 2) communication and information networks,
- 3) intercom, antenna and alarm systems,
- 4) lightning protection systems.

3. CURRENT STATE OF KNOWLEDGE ON FIRE BEHAVIOUR OF ELECTRIC CABLES

3.1. Electrical installations and cables

The first attempt at regulating electrical installations dates back to 1907 [38], while more recent contributions on this subject are [39, 40, 41, 42]. McClung and Hill [41] pointed out ‘a need to capture in one location the wealth of electrical system design techniques that have been published in recent IEEE papers and in other industry sources’. One of the newest national standards in this field is the British BS 7671 [43] published in 2008. In 2011, electric cables were put on the list of construction products in Europe [15].

A highly valuable and comprehensive critical review of the research on one of the most important types of structural fires – electric fires directly caused by the flow of electric current or by static electricity – was published by Babrauskas [44] in 2012, who summarised the state of the literature as follows: ‘Despite the importance of electrical fires, there has not been any institution in the English-speaking world with a long-term commitment to research in this area’. Current research in the field is ongoing in China and Japan [45].

Worldwide, the situation has been much better, due to extensive research in Japan. Most of this body of work, however, was only published in Japanese and, consequently, had been unavailable to most scientists and engineers in English-speaking countries. More recently, Barros and Diego [46] presented an extensive critical literature review of the main contributions in the principal aspects of power quality in ships, which has an application to buildings as well. They discussed voltage and frequency fluctuations, voltage dips and swells, transients and voltage notching, fault detection and classification, harmonic distortion and voltage imbalance. Moreover, power quality instrumentation and power quality regulations for electrical installations in ships were also considered. Most of these findings are certainly applicable to buildings as well.

The new fire research field has grown as a result of the increasing number of roof fires caused by photovoltaic installations [47, 48, 49, 50, 51]. Internal fires and their impact on residential electrical installations were also studied [52, 53, 54]. Some research on electrical installations

under fire conditions was performed for the purpose of tunnel safety [55]. Very few examples of modelling electrical installations have been previously performed [56, 57]. The final two contributions focused on risk analysis for the safety of nuclear plants. The fire behaviour of building products in the general context of fire safety was discussed by J. Fangrat in [58].

Some research on electrical installations under fire conditions was performed for the purpose of tunnel fire safety [55] yielding some general conclusions for building objects including buildings. In each existing tunnel, regardless of length, fire safety rules apply. Wires and cables placed in engineering constructions should be non-fire spreading. The tunnel should be made of non-combustible materials and have a fire resistance of not less than 240 minutes, while the interior design elements should be made of non-combustible materials. These requirements are not applicable to buildings. Equipment and installations constituting safety equipment should be made in a way that ensures their functioning in fire for the time necessary to carry out the evacuation. A tunnel with safety devices necessary for evacuation, powered by electricity, should have an emergency power supply capable of ensuring the operation of these devices until the users have left the tunnel [59].

In the case of underground tunnels, which are also building objects, the provisions regarding the fire properties of the materials used are included in the Regulation of the Ministry of Infrastructure of 17 June 2011 on the technical conditions to be met by underground constructions and their location. The ordinance says that electrical and optical fibre cables and wires, together with their fastenings, used in the power supply and control systems of fire protection devices, should ensure the continuity of electricity supply or signal transmission for the time required to start and operate the fire protection and evacuation devices. Unfinished tunnels and stations, including ceiling linings and suspended ceilings, passenger platforms, floors and stairs, ventilation ducts and their linings, as well as silencers and filters used in them should be made of non-combustible materials, whereas cladding, transparent coverings, staircases, partitions and screens, as well as other floor coverings and floors should be made from non-ignitable materials. At the same time, cables, wires and channels installed inside an underground should be at least “B-s3,d0” reaction to fire class, which only refers to wall and ceiling elements and not linear products such as cables [60]. The requirements for cables in tunnels, however, are “a drop in the sea of needs” for the overall requirements for buildings. The provision regarding cables and wires used in buildings is still not precise and does not apply to the reaction to fire of electric cables, but only to the building, con-

struction and finishing materials. Conversely, for cables used in construction objects, there are still no appropriate regulations regarding the reaction to fire of cables.

A number of experimental studies using various laboratory tests were performed and physical-based theories were proposed to describe the fire properties of electric wires and cables. The authors of the most recently published review on electric cables stated that: ‘the complex role of the conductor, specifically whether it is a *heat source* or *heat sink*, in the ignition, flame spread, burning, and extinction, has been emphasized throughout this review.’ They conclude that ‘a deeper understanding of fire phenomena in real wire and cable is still quite challenging, and attempted inferences for real wire fires based on the qualitative or semi-empirical analysis of limited laboratory data are not yet convincing enough [...] there is still a large gap between the fundamental research using laboratory wires and applied research using commercial wires’ [45].

3.2. Fire spread in buildings as a result of cable fires

Flame spread is defined as the ‘progress of flame over a surface’ or as the ‘rate of travel of a flame front under given conditions of burning’ [29]. Flame spread is critically affected by combustible gases evolved at the surface or in the interior of the material, which escape at the surface. Flame spread can transmit fire to more flammable materials in the vicinity and lead to flashover as a consequence [29].

Building products like electric wires and cables, and circuit electrical installations may cover a large surface inside buildings. It has been found that installations mounted on internal walls cause a significant decrease in fire properties, especially when made out of combustible substrate [61, 62, 63]. The large number of cables installed in buildings strongly increases their fire load and facilitates flame spread over a long distance (both horizontal and vertical) in the case of fire [45, 64, 65].

Electric wires have been tested separately or in cable trays. Real-scale horizontal oriented cable tests were conducted for investigating the effects of confined and ventilated conditions on cable tray fires and also their main consequences [66, 67]. Flame spread and fire growth have been shown to be predictable using a fire spread and growth (FSG) model developed at FMRC, alongside small-scale flammability measurements for PE/PVC cables [68]. Others have stated that ‘a simple and systematic way to rank the fire performance of insulated electrical cables [...] is particularly significant because of the complexity of the cables tested – the

cables have insulations of different compositions and interactions between the conductor and the insulation affect the fire performance' [22].

A fire in a building can spread from one cable tray to additional trays mounted above and/or horizontally from that one tray. Because of the high significance of cable fires, several research projects have been carried out, investigating the fire behaviour of cables ranging from small-scale, e.g. the cone calorimeter, to large-scale tests, analysing complete cable tray constructions. The influence of geometrical parameters, like packing density and tray distance, on the burning behaviour and fire spread of cable tray installations are important issues in the case of cable fires and have been discussed and compared with numerical simulation results [69].

Most cables already installed in buildings increase the fire load. Thermal properties and fire propagation performance were studied for new and aged electrical wires using a flame spread apparatus. The difference in thermal properties between new and aged electrical wires shows that the chemical composition and structure of polymer insulation changes due to thermal degradation and metal catalysis. The thermal ageing of old cables coupled with metal catalysis can promote degradation and change the thermal or fire spread properties of polymer materials [70].

One important characteristic of vertical cable tray fires is the time-varying upward spreading of the cable flame along the cable tray, which has been discussed for nuclear power plants. The experiments performed indicated that a room with a vertical cable tray fire could be divided into three zones with respect to thermal characteristics. The hazards from a vertically spreading fire in a compartment in nuclear power plants were also estimated [71].

The effects of flame spread in buildings have been discussed in chapter 2 of this monography.

3.3. Cable fire testing

Electric cables are now extensively used for both residential and industrial applications. For over more than twenty years, multi-scale approaches have been developed to study the fire behaviour of such cables, which represents a serious challenge. Cables are complex objects because they consist of insulation and sheaths made of polymeric materials of various chemical structures, thicknesses and additives [72].

The main problem in regards to the study of the fire properties of all building products is how to simulate real-scale scenarios with an adequate amount of data. The large number of cables, their construction

and extensive application in building objects strongly increase their fire load and ease flame spread over long distances (both horizontal and vertical) in the case of fire.

A number of geometric small- and large-scale tests for measuring heat, smoke and flame spread has been developed for better understanding the fire behaviour of electric cables. This has been widely investigated in horizontal conditions, i.e. the cone calorimeter method compared with the large-scale cable test, which shows good reproducibility and repeatability in the case of cable testing (FIPEC project) [23]. In this thesis, cable families were separated in order to decrease the number of tests for fire classification according to the EN 13501-6 standard [16]. Within the same family, cables differed in terms of conductor but the chemical structure of insulations and sheaths were the same. The cables differed in cable parameter χ , which is discussed in more detail in chapters 4 and 9.

In other studies, on small-scale cone calorimeter tests, it was found that the complex internal structure of cables complicates the investigation of pyrolysis and the combustion behaviour of cable sheaths when using the popular cone calorimeter method and full-scale experiments [73, 74]. Cables presenting non-planar surfaces show significantly different heat flux levels during cone calorimeter tests [75]. It was also previously found that the time for ignition is only dependent on heat flux, while the sheath delays the occurrence of the main peak of heat release rate (peakHRR) corresponding to the decomposition of non-flame retarded cable insulations [76]. In many cases, however, cone calorimeter equipment became a relevant method for estimating the full-scale fire behaviour of various products [77] such as cables.

The cone calorimeter method was also used for indicating the relationship between burning length and smoke visibility in the fire compartment affected by cable fires [78]. The authors of this article assessed the influence of electric cables on visibility on the basis of the critical smoke volume coefficient (the sum of the smoke volume in the smoke layer and the amount of smoke removed from the fire compartment), depending on the extent of cable damage. With a critical smoke volume, visibility in a fire is reduced to a certain limit (most often 10 m). It was found that the advantages of the test method compliant with the ISO 5660 specification (cone calorimeter) are independent on the dimensions and geometry of the area in which the reduction of visibility is assessed, as well as independent on the length and properties of the assessed electric cables and the optical properties (reflectance or brightness) of reflective signs indoors and simple practical application of the data thus ob-

tained. It was found that in order to ensure the visibility of reflective signs at a distance of 10 m (during the first 10 minutes of the fire duration), it is necessary to remove at least 8 m³ of smoke per meter of cable length from the fire zone. In order to ensure the same visibility of retro-reflective signs in the same period of time, at least 2.8 m³ of smoke per meter of cable should be evacuated from the fire compartment. After 30 minutes, the differences between the test results for the power and signal cables are noticeable because the signal cable showed a much lower critical ratio of smoke volume to the length of the burning cable than the power cables. The time dependence of the critical ratio of smoke volume to the length of burning wires for all tested electric wires turned out to be non-linear (with a maximum increase in the period from approximately 500 s to 1000 s).

The previous investigations pointed out that cables present in non-planar surfaces would experience significantly different heat flux levels during cone calorimeter tests [23]. It was found that the time to ignition is only dependent on heat flux, while the influence of the sheath concentrates on delaying the occurrence of the main peak HRR corresponding to the decomposition of non-flame retarded insulation [75]. It was also discussed that the temperature at flashing ignition points of cable materials is mostly affected by the polymer structure and exothermic reactions as an effect of the content of various additives and does not necessarily reflect the flame retardancy of the material [79].

Other investigations on cone calorimeter testing have pointed to the significant influence of heat flux, the composition and structure of the cable, as well as the fire properties of the cables and any changes in cable specimen layout [80]. In most cases, cone calorimeter equipment was the most relevant method for estimating the full-scale fire behaviour of various products [76, 77], including cables.

3.4. Fire tests in microgravity

Fire research in microgravity conditions is a scientific field dating back to the 1960s [81, 82]. Space expeditions have brought focus on how fire that would break out in a spacecraft or space station can spread and what is the threat it will pose. Due to the specific conditions of the research, there were few centres dealing with this topic and very few publications addressing the issue. One is the National Aeronautics and Space Administration (NASA) in the United States of America.

Earlier studies have been undertaken by researchers [83, 84] from NASA. The authors discussed low-gravity combustion, with implications

for fire safety. The conclusion from the studies was that in orbiting spacecraft, the detection and suppression of flames are strongly affected by the large reduction in buoyant flows under low gravity and that, in these conditions, combustion intensity is reduced. The authors also examined future requirements in fire safety, particularly the long-term needs of space stations for fire prevention, detection, extinguishment and atmospheric control. The goal of spacecraft fire safety investigations was the establishment of trade-offs that promote maximum safety without hampering human and scientific activities in space [83].

Microgravity conditions are similar to those in outer space. The fire tests performed by NASA play a key role in space station and spacecraft fires. In 1998, NASA issued a technical report, NASA-STD-6001 [85] containing the flammability, odour, off-gassing, and compatibility requirements and test procedures for materials in environments that support combustion. This document established the requirements for the evaluation, testing and selection of materials that are intended for use in space vehicles, associated ground support equipment, and facilities used during assembly, test and flight operations [85].

The study of modern materials used in space vehicles and space stations and their fire behaviour are still a prominent research topic worldwide. A series of flight experiments named SAFFIRE 1, 2 and 3 have been conducted in an Orbital Science Corporation Cygnus vehicle undocked from the International Space Station (ISS). Their aim was to show the risks in the design of spacecraft fire safety systems. These and subsequent SAFFIRE experiments addressed questions such as how much fire suppressant is required to extinguish a plausible spacecraft fire or how much sorbent material is required to clean up a habitable volume in a specified period of time following a fire [86]. Some of the conditions experienced by microgravity flames show that fires behind walls or inside electronic equipment involve flame spreads in narrow gaps [87].

An attempt was made as part of the SAFFIRE project to understand fully fire spread in spacecrafts by fire modelling and the comparison between normal gravity and microgravity fire experiments on thermally thin materials (fabric) [88, 89]. International teams collaborated with the NASA team in defining the experiment requirements and performing supporting analysis, experimentation, and technological development. It was shown that no single experiment can address the range of issues that need to be resolved in order to understand fully spacecraft fire risk and to ensure the safety of future flights. Flight experiments are validation experiments and require substantial support from experimental

campaigns involving ground testing, parabolic flights and space station experiments.

The thermally thin materials were fire tested in order to investigate flammability and flame spread in microgravity conditions [90]. Flame spread tests were used to develop correlations for the effects of flow velocity, oxygen concentration and pressure on flame spread rate.

Research in space fire safety is being carried out not only in the United States but also in Japan. The Micro Gravity Laboratory of Japan (MGLAB) conducted some microgravity experiments to explain the ignition phenomena of overloaded electric wires. In the experiments, the current supply duration was selected as the main test parameter in order to simulate the status of the circuit breaker shortly after overload occurs. Other important test parameters were the oxygen concentration and the supplied electric current amount. The results showed that the microgravity conditions significantly increase ignition probability, including the occurrence of delayed ignition and extended ignition limits, with large electric currents compared with normal earth-based gravity [91].

The same research team investigated the flammability of polyethylene (PE) insulated wires [92]. The ignition limit was shown to be extended in microgravity conditions. It was found that the actual lowest limit by the ground-based microgravity facility is not straightforward and requires a database obtained over long-term experiments, as other investigations.

There is still a gap, however, in the fire testing of cables and electric wires in microgravity conditions, although they are widely used in space stations and space vehicles.

3.5. Numerical simulations of cable fires

Various research methods are also being developed in order to eliminate large-scale reaction to cable fire tests and simplify them [93, 94]. There is currently a trend to develop computer simulations of cable fire behaviours by prediction using alternative reaction models, which are compared to experimental results [95]. There has also been an attempt to create a kinetics model by using thermal parameters estimated by the Thermogravimetric Analysis (TGA) and cone calorimeter data from PVC insulated and sheathed cables [96].

It was found that cables have a char-forming tendency when exposed to a heat source [72]. Therefore, the pyrolysis mechanism and the flammability of cables have been investigated. The experimental data obtained for two types of cable commonly used in French nuclear power plants were compared with the numerical simulation data based on the

description of cable mass loss, coupling an Arrhenius expression with a 1D thermal model of cable heating. The numerical results were then compared with experimental data. The spontaneous or piloted ignition investigations of these cables were also studied [72].

Currently, fire safety in tunnels, as building objects, plays an extremely important role, especially where a large amount of cables is installed. In order to obtain the optimised control modes for smoke propagation and better environmental conditions for inspection, maintenance and personnel evacuation, different modes of ventilation systems, fire-proof doors and sprinklers in case of fire must be combined. The Fire Dynamics Simulator (FDS) was adopted to investigate the effectiveness of these modes during fire in a tunnel. The results showed that the optimisation of smoke control modes in the utility tunnel depends significantly on the cooperation of the air supply system, air exhaust system, sprinkler system and the appropriate switch modes of fire-proof doors at different stages of fire development [97].

The same method (FDS) was used for the pyrolysis reaction simulation. The flame-retardant cables were investigated using TGA to measure the reference temperature and rate required for fire spread simulation. A two-step pyrolysis reaction was observed regardless of the cable type, and each pyrolysis reaction could be attributed to a single or multiple component depending on the cable type and reaction order. The structures, compositions, and insulation performances of the cables differed considerably and the reference temperatures of the two-step pyrolysis reaction were similar regardless of cable type. The analysis indicated that the mean values of the reference temperature and rate are sufficient to simulate the pyrolysis reactions of flame-retardant cables. The conclusion from the research was that heat transfer and the pyrolysis reaction path associated with the multi-layered cable structure may be more important for determining the ignition and fire spread characteristics, which are dependent on cable construction, composition and insulation performance [98].

The simulation of the multi-layered cable tray fire presents a challenge for fire models. By developing a more accurate fire source description, the FLASH-CAT model has been used. In this method, the HRR of each burning cable tray is taken for evaluation. The zone model was applied to predict the fire dynamics process. In order to validate the used method, four-layer cable tray fire experiments and replicated experiments were carried out in a confined compartment. The data of mass loss rate of the cable tray, temperatures at the middle of the compartment, vertical temperature profile and the total heat release rate were

recorded. The comparisons between simulations and experimental data showed that the predicted upper- and lower-layer temperatures agreed well with the experimental data [99]. The authors developed a more detailed description of the fire source than the one used so far in numerical modelling. They used the so-called the semi-empirical model FLASH-CAT (Flame Spread over Horizontal Cable Tray). In this method, the HRR from each burning cable tray was used for evaluation. A zone model was used to predict the fire dynamics process. In order to validate the method used, fire experiments were carried out with four-layer cable trays. The experiments were repeated in a closed room. Data on the rate of cable tray weight loss, mid-time temperatures, vertical temperature profile, and total room HRR were recorded. Comparison of the simulation and experimental data showed good agreement of the model with the experiment for upper- and lower-layer temperatures. As a result, the FLASH-CAT method was found to provide a reliable and fast prediction of the combustion of a multi-layer cable tray. A similar investigation was performed in another project for nuclear power plants, where a large amount of cables was installed [100].

The general applicability of flame spread, packing density and tray distance parameters as input data for the parametrisation of the source term of numerical simulations has also been shown elsewhere. The test results showed that burning behaviour and fire spread depend on the cable arrangement on the cable tray, in combination with other boundary conditions. By applying the results as input for a fire simulation, the mass loss rate was also a suitable tool [69].

The computational fluid dynamics (CFD)-based modelling method for the prediction of cable tray fire development was also used. The five horizontal trays of 49 power PVC cables were tested in order to evaluate the numerical simulation method. An 80kW propane burner was used for the fire experiments. The thermal properties and surface ignition temperature of cables were estimated from cone calorimeter tests. The heat release profile obtained from the cone calorimeter tests, rather than the point peakHRR was reached, has been proposed for simulations [101].

Numerical simulations of the fire properties of cables were also carried out for an L-type corridor under different fire source location height conditions. The temperature changing rule of the inflection point of the L-type corridor was discussed and the temperature prediction formula was established based on the height of the ignition source at different stages according to the fire situation. The study showed the obvious smoke accumulation effect in L-type cable corridors [102].

There is no simple and short answer to the question regarding the issue of numerical modelling of fire development and fire properties, because it is a very complex and multi-threaded issue in which numerous research teams specialize. Literature reports are not unequivocal and do not allow for far-reaching generalizations, let alone assess the quality of numerical modelling in this area.

3.6. Fire effluent toxicity

Smoke inhalation, as well as burn injuries and oxygen depletion, is a serious health threat to victims of house fires, explosions, and other disasters involving fire and smoke [103]. Inhalable particles in fire effluents have acute toxic potency by transporting toxicants deep into the lungs. If the concentration of particles is high, their inhalation can lead to lung inflammation hours later, assuming that the person escapes the immediate fire threat [104].

Fire deaths from toxic gas inhalation occur predominantly after fires have progressed beyond the stage of fire when the total surface of combustible material is set on fire within an enclosure [2] (flashover). Fire victims are usually found in a room other than the one that is on fire (so-called room of origin), which clearly demonstrates how important fire effluent toxicity is from the point of view of fire safety [105].

Fire effluent toxicity is a function of four factors: the amount of materials burnt, the distribution of combustion products within the smoke, the individual toxic potencies of each combustion product found in the vapour phase and the duration of exposure [106].

Fire effluent toxicity can be characterised according to the time period post-injury, as discussed in detail by Matthew et al. in [107].

A significant number of studies has been conducted on fire effluent toxicity so far. Many focused on the development of test methods, as well as the qualitative assessment of fire gases present in fire effluents from pure polymers (low density polyethylene (LDPE), polystyrene, polyamides and PVC) under various fire conditions. The different behaviour of combustion processes of PVC compared with other polymers related to the dehydrochlorination process and subsequent cross-linking was shown. Also, soot formation was studied for pure polymers in the form of pellets [19, 26, 27, 108, 109, 110, 123]. Yasuhara et al. [111] investigated the amount of polychlorinated dibenzo-*p*-dioxins and dibenzofurans under different fire conditions. They argued that chlorine-containing compounds in fire effluents are relatively low.

Smoke toxicity or the toxicity of smoke, combustion toxicity and fire toxicity are terms often used interchangeably (even within a single publication) in the current scientific literature on toxicity under fire conditions, among others by Yates [112], Purser [113], Stec and Hull [114], Alarie [115], Beitel et. al. [116]. This nomenclature is also not harmonised by international standards on terminology regarding fire safety, for instance [2, 11, 117].

'Smoke toxicity' has been defined by Beitel et al. as 'the propensity of smoke to produce adverse biochemical or physiological effects' [116], whereas smoke refers to the visible parts of fire effluents, which consist of solid and/or liquid particles. The term 'combustion toxicity' used by Purser [113] refers only to the toxic effect of combustion processes, where flame occurs and fire effluents are evolved. The pyrolysis process has not been considered in this case.

'Fire toxicity', as defined in standards [11, 117], has a broader meaning as 'the largest cause of death and injury in fires' and covers all harmful effects for fire victims as:

- 1) convective and radiative heat-caused burns,
- 2) irritation of respiratory tract, eyes and skin as an effect of acid gases and organic irritants present in fire effluents,
- 3) asphyxiant effect caused by hyperventilation, inhalation of smoke and oxygen depletion,
- 4) lethality as an effect of toxic gas (such as CO, hydrogen cyanide, benzene and other gaseous species produced in fires) inhalation [115].

Invisible parts, such as fire gases, cause the most harmful effects on living organisms, which are usually called 'fire toxicity' [2, 11, 114, 117]. The phrase 'smoke toxicity', which is often used by Yates [112], appears too narrow because it only refers to solid and liquid visible particles, while most hazardous fire gases are ignored. In conclusion, "fire effluent toxicity" seems to be the most appropriate term to describe the toxic hazard of smoke and gaseous toxic species in the mixture/aerosol of fire effluents.

Moreover, bearing in mind that fire was defined as 'a process of combustion characterised by emission of heat accompanied by flame and fire effluents' [2, 117, 118], it is directly linked to the term "fire effluents toxicity". Fire effluents generated during combustion or pyrolysis processes consist of a highly complex mixture of liquids and solid smoke particulates and gaseous vapours [117, 119]. They also contain a large number of substances, which in many cases are toxic. The range and yields of toxic substances generated during combustion depend on the composition of the material (fuel) and the decomposition conditions [120].

The current laboratory method of testing toxicity under fire conditions [121] is based on highly controlled combustion in terms of volume, temperature and pressure conditions unlike in real fires, where uncontrolled combustion has always been involved.

In general, combustion and pyrolysis processes differ in the presence of a flame and a substance with an oxidising agent in the fire zone. The pyrolysis process is forced only by heat and is usually observed before flaming combustion [2, 11, 116]. The mechanisms of both processes are irreversible and depend mainly on the nature of the materials, which exothermally react together and on the accompanying fire conditions [122].

Finally, it is necessary to bear in mind that toxicity is expressed per volume unit. Contrary to a real fire situation, where the volume occupied by smoke, and the temperature and flow rate conditions change variably during fire development, with the flame spread rate depending on numerous factors, for instance the location of architectural elements like building partitions and openings or other internal equipment obstacles and ventilation systems, in the laboratory method of testing toxicity the volume of the test vessel remains constant, while the temperature level and flow rate are under control. For this reason, this laboratory method is not a precise reflection, model or scenario of real fire conditions. Therefore, laboratory test results on toxicity have very limited, if any, applicability to a real fire situation. Comparative analysis of building products and materials, however, is possible. On this basis, for example, one can set them in order of increasing or decreasing toxicity values. This type of information is necessary, although numerical simulation and further theoretical analysis is very difficult or even impossible by means of these data.

Summarising, the term “fire effluent toxicity” is the most precise in the author’s opinion and will, therefore, be used further in this study.

Quantitative analysis of the toxic products from burning cables has been found to be challenging. It was shown in an earlier study by the author that even under well-ventilated conditions, when most materials indicate stable burning, cables did not burn continuously [123] for very high temperatures (approaching 900°C).

The decomposition mechanisms of pure PVC and PVC with additives during the pyrolysis process were studied by means of TGA-FTIR by Zhu et al [124] and McNeill et al. [125]. They proved the release of hydrogen chloride (HCl) and high amounts of hydrocarbons (HCs) in fire effluents. Almost all chlorine transforms into HCl, and only a little amount of other chlorine-contained species was detected. The authors [125] performed research with various instrumental techniques and conducted an exten-

sive qualitative analysis of PVC pyrolysis products, dioctyl phthalate (DOP) plasticizer (bis(2-ethylhexyl)phthalate (DEHP)) and plasticized PVC with DOP. They found that during the combustion process, PVC produces HCl and a significant number of aromatic and alkylaromatic compounds. The products of DOP pyrolysis were benzene, toluene, benzaldehyde, phthalic anhydride, iso-octenes, unsaturated ketones and alcohols. In the pyrolysis process of the PVC-DOP mixture, apart from the individual products of PVC and DOP pyrolysis, radical reaction products were formed. The quantitative analysis of PVC combustion products has not been performed. On the other hand, in [124], the authors estimated the amount of HCl released during the pyrolysis of PVC with an admixture of CaCO_3 , CaO and $\text{Ca}(\text{OH})_2$ fillers. PVC pyrolysis with fillers was carried out with TG-FTIR. It has been shown that almost all chlorine is converted to HCl, and its efficiency varies depending on the filler used. The fillers used acted as agents limiting the release of HCl by binding chloride radicals. The HCl yield decreased with increasing Ca/Cl molar ratio.

The pyrolysis and combustion properties of new and aged PVC sheathed cables were investigated by Wang et al. [126]. The following test methods have been used for investigation: TGA, Fourier Transforms Infrared (FTIR), microscale combustion calorimetry (MCC) and cone calorimeter. It was discovered that an aged sheath underwent incomplete and weakened pyrolysis and combustion processes.

A recent study by Chong et al. [127] contains a detailed analysis of HCs, which was carried out on PVC pipes. Infrared spectroscopy and gas chromatography-mass spectrometry (GC-MS) analyses showed the presence of chlorinated components, including chlorine dioxide, methylene chloride, allyl chloride, vinyl chloride, ethyl chloride, 1-chlorobutane, tetrachloroethylene, chlorobenzene, HCl, benzene, 1,3-butadiene, methyl methacrylate, CO, acrolein, formaldehyde and many more long-chain HCs. In the first stage of PVC thermal decomposition at a temperature of $210^\circ\text{C} - 245^\circ\text{C}$, HCl was released. In the second step ($245^\circ\text{C} - 300^\circ\text{C}$), the process proceeded from a cross-linked portion of the polymer with hinderedness. Weight loss of 18.31% took place consecutively at temperatures up to 450°C , and the last phase of weight loss 19.25% was completed at a temperature of about 700°C . The last two stages of weight loss are related to the degradation of long-chain HCs, the formation of siloxanes and CO_2 . The residue after TGA (up to 1000°C) was examined by FTIR spectroscopy. A mixture of calcium carbonate and silicates was detected, which was used as a filler in the production of PVC pipes. The smoke generated from the combustion of the tested pipes consists of

volatile compounds, which are mainly alkenes, aromatic compounds and chlorine-containing compounds such as HCl, chlorine dioxide, 1-chlorobutane, vinyl chloride, ethylene dichloride and chlorobenzene. The results were confirmed by gas chromatography – mass spectrometry (GC-MS) tests.

Unplasticised PVC is a rigid polymer, which is susceptible to dipole interactions between chlorine atoms. In order to increase flexibility, it is necessary to weaken intermolecular interactions and increase the mobility of macromolecules (lowering the glass transition temperature), instead of copolymerization with comonomers e.g. vinyl acetate, vinylidene chloride, acrylonitrile, introducing physical plasticisers (for instance, dioctyl phthalate, tricresyl phosphate) [128].

Previous investigations carried out by Hirschler [19] have pointed out that materials made of unplasticised (rigid) PVC (e.g. wall claddings) showed ‘much better fire properties’ than plasticised (flexible) PVC (e.g. electric cables), which is due to the addition of phthalates, for example, which ‘have even worse fire properties than PVC itself’. The described study was based on the investigation of PVC in several aspects, such as ignitability, ease of extinction (oxygen index), flame spread (small scale and intermediate scale), heat release, smoke obscuration, smoke toxicity, HCl emission and decay, and performance in real-scale fires. Using a combination of plasticisers and fillers, such as antimony trioxide or aluminium trihydrate (ATH), in the case of plasticised PVC, significantly improved the fire properties of PVC used, for example, in cable production [19, 129]. Inorganic fillers, such as antimony trioxide, alumina trihydrate, zinc hydroxystannate and zinc borate (ZnB) act as flame retardants of PVC. At present, however, a significant number of flame-retardant additives improves the fire properties, including those associated with the emission of smoke and toxic combustion products, of plastics based on plasticised (flexible) PVC [130, 131, 132].

4. SCIENTIFIC PROBLEM

The fire resistance of building classes (ZL) mentioned in chapter 1 are related to the fire reaction of construction products, interior finishing elements etc. Electric cables, used in large quantities in buildings, are also building products and have been included in the group of construction products in the CPR Regulation. They provide electricity and signal to various receivers, which is why they are clearly divided into types according to their purpose (Fig. 7).

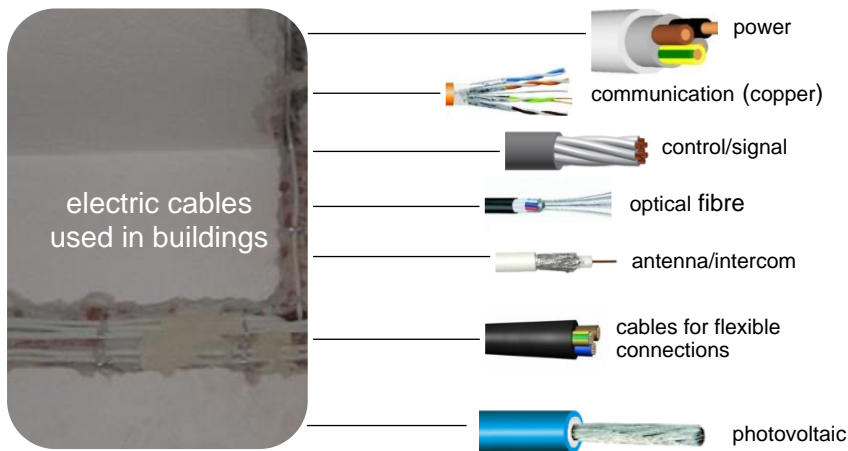

Fig. 7. Types of typical cables according to end-use application in buildings

Recently, photovoltaic cables (Fig. 7) for photovoltaic installations and hybrid cables are gaining in importance, combining several applications simultaneously (Fig. 8).

Due to the significant risk of fire in a building with a significant number of cables routed in it, as a result of both a short circuit in the electrical system and the progressive fire spread within the building, it is absolutely necessary to provide the constructional and material parameters of the cables affecting the fire properties of buildings. A major concern is the selection of electric cables according to their fire properties. The scale of the impact of individual constructional-material parameters on the

fire properties of a building is the main issue raised in this monography based on the doctoral dissertation [5].



Fig. 8. Hybrid cable

Unlike most earlier studies published so far, the motivation for the present work was not to design another experimental method, but to investigate the effect of material and constructional parameters on the fire behaviour of electrical cables in a systematic way. To the best of the author’s knowledge, such systematic research has not been published so far. The present study is, thus, original, filling this research gap.

Five major groups of constructional-material parameters concerning cables were chosen for the analysis (Fig. 9) [64].

1. Conductor construction material	<ul style="list-style-type: none"> • copper • aluminium
2. Conductor cross-section	<ul style="list-style-type: none"> • round • sector
3. Number of conductors	<ul style="list-style-type: none"> • single-conductor • multi-conductor
4. Non-metallic elements	<ul style="list-style-type: none"> • PVC • non-halogenated
5. Concentric barrier	<ul style="list-style-type: none"> • armoured • non-armoured

Fig. 9. Different constructional-material parameters of cables [64]

The groups (Fig. 9) were developed during the investigation of the nature of factors affecting the fire properties of electric cables, and the impact of constructional-material parameters on the fire properties of cables (Fig. 10) was proved by performing a number of experiments.

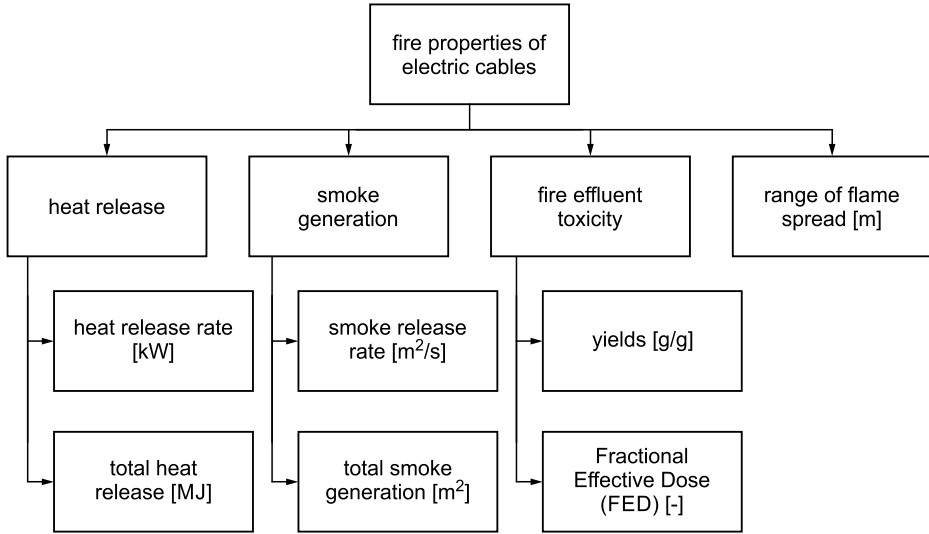

Fig. 10. Fire properties of electric cables

Under fire conditions and easy oxidation, a large amount of heat and smoke is produced. Electric cables may present different behaviour under the same fire conditions. The main aim of the study was to identify relevant factors related to the construction and content of electrical cables, and provide a qualitative and quantitative assessment of their influence on the specific fire properties of these building products.

The fire properties of each cable are accumulated in one standardised cable parameter χ (2) [1, 138]

$$\chi = \frac{n}{d_{\text{cable}}^2} V_{\text{combust}} \quad (2)$$

where:

- χ – cable parameter [-],
- n – number of conductors [-],
- V_{combust} – non-metallic volume of combustible cable components, $\text{m}^3/1 \text{ m}$ bunched cable according to EN 50399 [4],
- d_{cable} – diameter of cable [m].

According to the above empirical equation (2), cable parameter χ is directly proportional to the number of conductors (n) and non-metallic volume of combustible cable components in 1 m of bunched cable (V_{combust}), and inversely proportional to the square of the diameter of the cable cross-section (d_{cable}^2).

A simple relationship between the value of cable parameter χ and the number of conductors (n) is met for cables with less than 19 conductors. For a greater number, however, it is conditioned by the growth of parameters associated with heat release rate (HRR), total heat release (THR), total smoke production (TSP) and smoke release rate (SPR), despite the increasing content of the V_{combust} . This means that only one construction characteristic is considered, while it was shown in the tests performed that this is not the only characteristic, which influences the fire properties of the product. In other words, empirical equation (2) defined parameter χ and contains the V_{combust} . In spite of that, parameter χ does not clearly identify the fire properties of the product, because the same value of χ may lead to different fire properties. Thus, on the basis of the research performed, the author found low accuracy in the description of the fire properties of cables by the cable parameter χ . On the basis of the in-depth analysis, another empirical formula that expresses this relationship with greater accuracy has been proposed.

This thesis focused on the relationship between the construction of the cables and their fire properties, which, however, does not depend on a simple and obvious deterioration of fire properties as the amount of flammable materials in the construction increases. A parameter which includes both metallic barriers and the amount of the combustible non-metallic contents of cables is essential for this study.

A number of studies has been conducted so far on the influence of PVC on the fire properties of materials, i.e. [13, 22, 23, 24, 68]. Cables which vary in more than one constructional parameter, however, were used in these investigations rendering their results not comparable with those presented here.

Thus, the scientific problem as considered in the cited doctoral dissertation [5] is to determine the impact of the relevant constructional and material parameters of cables on their fire properties by establishing qualitative and, where possible, quantitative relationships between these factors. Thus, the purpose of this research is to identify relevant factors related to the construction of electrical cables used in buildings, and a qualitative and quantitative assessment of their influence on the chosen fire properties, such as heat and smoke release, range of flame spread (FS) and toxic effluents under fire conditions, and the impact of electric cables on the fire safety of buildings.

Several experimental methods, and complementary theoretical analysis based on Quintiere's theory, were applied to address this scientific problem [133, 134, 135, 136]. To the best of knowledge of the author of the monography, this analysis of Quintiere's theory has not been carried out for electrical cables used in buildings so far.

5. CONSTRUCTIONAL AND MATERIAL PARAMETERS OF STUDIED CABLES

PVC is the most popular material for cables below 1 kV voltage rating. The use of modern materials, however, such as those of low-smoke zero-halogen cables (LSOH) formulation tend to be popular worldwide and need to be investigated in the case of the fire behaviour of electric cables.

Electric cables are usually built of metallic (copper or aluminium) conductors and, optionally, concentric conductors (copper or aluminium), steel armour or screens [137]. Cable insulations, outer sheaths and, optionally, bedding or various separators and tapes are built of combustible synthetic materials [64, 138, 139, 140]. The volume of tapes is less than 1% of all non-metallic elements of the cables and those elements do not significantly influence their fire properties. The materials used for cable sheaths and insulations must, first of all, meet functional properties, i.e. electric shock (insulation) and mechanical properties.

The most important elements of cable construction are metallic conductors (conductors) built of copper or aluminium wires. Conductors are distinguished by different cross-sections depending on their end-use application and electrical properties [141].

Depending on the type, the conductors can be divided into the following classes:

- a) class 1: single-wire round conductors (Fig. 11 a),
- b) class 1: single-wire sector-shaped conductors (Fig. 11 b),
- c) class 2: multi-wire round conductors (Fig. 11 c),
- d) class 2: multi-wire sector-shaped conductors (Fig. 11 d),
- e) classes 5 and 6: flexible conductors (Fig. 11 e).

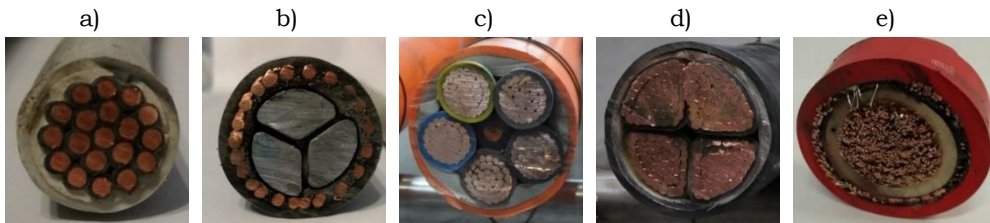

Fig. 11. General views of types of conductors (conductors) in typical power cables

The outer sheath, bedding (inner covering), insulations and central fillers (optionally) are built of non-metallic (synthetic) materials in the extrusion processes of thermoplastics and thermosetting materials moulded via a cross-linking process. The most important advantage of thermosetting materials is their resistance to high temperatures and deformations [142].

More than 90% of electric cables are produced from halogenated materials, such as PVC, chloroprene (CP), chlorinated polyethylene (CM), chlorosulphonic polyethylene (CSM), polytetrafluoroethylene (PTFE), a copolymer of tetrafluoroethylene/hexa-fluoroprophylyene copolymer (FEP), tetrafluorethylene copolymer and perfluorinated vinyl ether (PFA), with an addition of various fillers, stabilisers etc. The entire cables or separate construction elements can be formulated with a halogen-based material. During the combustion process of the halogenated materials, dense smoke, HCl or hydrogen fluoride (HF), and organic species containing chlorine or fluorine atoms in their structure are produced. The acidity of fumes can damage electronic devices and cause irritation and damages in the respiratory tract of humans [123, 143].

The halogenated materials are slowly displaced by LSOH cable insulation and sheathing materials. Such type of materials used for cable formulation are, for instance, ethylene-vinyl acetate copolymer (EVA), low-density polyethylene (LDPE), linear low-density polyethylene (LLDPE), high-density polyethylene (HDPE), polypropylene (PP), non-vulcanised rubber (EPDM), silane cross-linked polyethylene (XLPE), polyurethane elastomers (EPU) and polyamides [29]. The addition of inorganic fillers, such as silica, modified montmorillonite, modified bentonite clay, ATH, borates (e.g. ZnB) and melamine triazine, improves the fire properties of materials used for non-halogenated cable formulations [144, 145, 146, 147].

The EVA copolymer with the addition of ATH and ZnB has been recently used as a LSOH material for cable formulations showing good flame-retardant properties. ZnB has a synergistic effect with aluminium hydroxide and is often used in combination with other flame retardants. ZnB behaves like aluminium hydroxide by the endothermic release of water, but its main flame-retardant effect results from the formation of a glassy layer on the material surface [123, 148]. Significantly reduced fire parameters (mostly smoke) were also obtained for cables insulated with silane XLPE [149].

ATH is the most widely used inorganic flame retardant because of its easy incorporation into plastics. The fire retardancy mechanism is initiated once heated. It is well known that ATH decomposes and releases water (3), which tends to exclude air and dilute flammable gases. This

endothermic reaction results in a stable, at high temperatures, intumescent Al_2O_3 layer formulation [147, 148, 150, 151, 152].



The EVA copolymer has an important role in intumescence structure formation. Even better results were obtained with the addition to EVA of an intumescent system, which is a combination of melamine phosphate and phosphate-phosphonate substituted trimethylamine [153].

Existing old cables for electrical installations in buildings may be coated with compounds that form an intumescent layer at high temperatures to improve their fire properties. An example of such an application may be the composition of ammonium polyphosphate with other components, such as titanium dioxide, melamine, pentaerythritol, ATH etc. [154, 155] or phosphates, amides, various polyols, propanediono complex of molybdenum and vinyl acetate/vinyl versatate copolymers [156]. Ammonium polyphosphate with a high ammonia content helps to create a foamed char, which protects a surface from flame, heat and oxygen access to the combustion zone. Polyol, as an activator, is also needed [147].

Typical representative cables were chosen for the investigation of the impact of constructional-material parameters on the fire properties of electric cables used in buildings. They represent the possible range of cables produced and typically used in Europe (Tab. 2).

The representative cables with specific parameters selected for investigation differ in:

- 1) construction materials of conductors,
- 2) conductor cross-sections,
- 3) number of conductors,
- 4) non-metallic materials of cables,
- 5) armour and concentric conductors' occurrence.

The test results for eighty-three commercial power and communication (copper or aluminium) cables have been presented to show the strong relationship between the constructional-material parameters and fire properties of cables expressed as χ parameter (Tab. 2). Five cable samples (positions Nos. 23/60, 28/80, 29/74, 31/78, 48/89 in Tab. 2) had the characteristics of two constructional-material parameters; therefore, they were presented twice, and one cable sample (positions Nos. 36/65/84) three times. Cable samples in individual groups (I – V) were sorted according to the increasing values of cable parameter χ .

For the number of conductor parameters and, hence, the new concept of cable parameter investigation, six cables with a low number of conductors were used as power cables only, and cables of more than seven conductors were control cables.

Table 2. Characteristics of cable samples divided into various groups based on constructional–material parameters

Group No.	Cable sample No.	Characteristics						
		Conductor Size	Conductor Material/ Shape	Outer Sheath	Armour or Concentric Conductor	Bedding	Insulation	χ
I	1	1 × 630 mm ²	Al/round	LS0H compound	none	LS0H compound	XLPE	1.6
	2	1 × 300 mm ²	Cu/round	LS0H compound	none	none	XLPE	2.1
	3	3 × 300 mm ²	Cu/sector	LS0H compound	Cu tape and wires	LS0H tape	XLPE	3.9
	4	3 × 300 mm ²	Al/sector	LS0H compound	Cu tape and wires	LS0H tape	XLPE	4.1
	5	3 × 240 mm ²	Al/sector	LS0H compound	none	LS0H compound	XLPE	5.2
	6	3 × 300 mm ²	Cu/sector	LS0H compound	none	LS0H compound	XLPE	6.2
	7	3 × 50 mm ²	Al/sector	LS0H compound	galvanised steel wires	LS0H compound	XLPE	6.9
	8	3 × 50 mm ²	Cu/round	LS0H compound	galvanised steel wires	LS0H compound	XLPE	7.1
	9	4 × 35 mm ²	Al/sector	LS0H compound	galvanised steel wires	LS0H compound	XLPE	9.3
	10	4 × 25 mm ²	Cu/sector	LS0H compound	galvanised steel wires	LS0H compound	XLPE	11.6
	11	4 × 35 mm ²	Cu/sector	LS0H compound	Cu tape and wires	LS0H tape	XLPE	11.7
	12	4 × 35 mm ²	Al/sector	LS0H compound	Cu tape and wires	LS0H tape	XLPE	11.7
	13	4 × 50 mm ²	Al/sector	LS0H compound	none	LS0H compound	XLPE	11.8
	14	4 × 35 mm ²	Cu/sector	LS0H compound	none	LS0H compound	XLPE	13.9

Group No.	Cable sample No.	Characteristics						
		Conductor Size	Conductor Material/Shape	Outer Sheath	Armour or Concentric Conductor	Bedding	Insulation	χ
II	15	3 × 300 mm ²	Cu/round	LS0H compound	Cu tape and wires	LS0H compound	XLPE	4.0
	16	3 × 300 mm ²	Cu/sector	LS0H compound	Cu tape and wires	LS0H compound	XLPE	4.5
	17	3 × 70 mm ²	Al/sector	PVC FR	Al wires	PVC	XLPE	7.5
	18	3 × 70 mm ²	Al/sector	PVC FR	Cu tape and wires	EPDM	XLPE	8.3
	19	3 × 35 mm ²	Al/round	PVC FR	Al wires	PVC	XLPE	9.0
	20	3 × 50 mm ²	Al/round	PVC FR	Cu tape and wires	EPDM	XLPE	9.3
	21	4 × 35 mm ²	Cu/sector	LS0H compound	galvanised steel wires	LS0H compound	XLPE	9.6
	22	4 × 25 mm ²	Cu/round	thermoplastic LS0H	galvanized steel wires	LS0H compound	XLPE	9.7
	23	4 × 50 mm ²	Al/sector	PVC FR	Al wires	PVC	XLPE	10.2
	24	4 × 25 mm ²	Cu/sector	thermoplastic LS0H	galvanized steel wires	LS0H compound	XLPE	10.8
	25	4 × 35 mm ²	Cu/round	LS0H compound	galvanised steel wires	LS0H compound	XLPE	11.0
	26	4 × 50 mm ²	Cu/sector	LS0H compound	none	LS0H compound	XLPE	11.5
	27	4 × 16 mm ²	Al/round	PVC FR	Al wires	PVC	XLPE	13.8
	28	4 × 25 mm ²	Cu/round	LS0H compound	none	LS0H compound	XLPE	15.6

Group No.	Cable sample No.	Characteristics						
		Conductor Size	Conductor Material/Shape	Outer Sheath	Armour or Concentric Conductor	Bedding	Insulation	χ
III	29	3 × 240 mm ²	Cu/round	EVA/ATH/ZnB	Cu tape and wires	none	mica+silane XLPO	4.3
	30	1 × 16 mm ²	Cu/round	LSOH compound	none	none	mica tape+XLPE	8.7
	31	2 × 16 mm ²	Cu/round	LSOH compound	none	LSOH compound	mica tape+XLPE	10.7
	32	1 × 240 mm ²	Cu/round	EVA/ATH/ZnB	none	none	mica+silane XLPO	14.0
	33	1 × 1.5 mm ²	Cu/round	EVA/ATH/ZnB	none	none	silane XLPO	15.8
	34	2 × 1 mm ²	Cu/round	LSOH compound	Al/PET tape	none	silane XLPO	20.5
	35	1 × 1.5 mm ²	Cu/round	LSOH compound	none	EPDM	XLPE	21.5
	36	3 × 1.5 mm ²	Cu/round	EVA/ATH/ZnB	none	none	silane XLPO	26.4
	37	1 × 2 × 0.8 mm	Cu/round	LSOH compound	Al/PET tape	none	mica tape+LSOH compound	28.5
	38	1 × 1.5 mm ²	Cu/round	LSOH compound	none	none	XLPE	31.4
	39	2 × 2 × 2.3 mm	Cu/round	LSOH compound	Al/PET tape	none	mica tape+LSOH compound	47.7

Group No.	Cable sample No.	Characteristics						
		Conductor Size	Conductor Material/Shape	Outer Sheath	Armour or Concentric Conductor	Bedding	Insulation	χ
III	40	5 × 1.5 mm ²	Cu/round	LS0H compound	none	LS0H compound	XLPE	52.9
	41	2 × 2 × 0.8 mm ²	Cu/round	LS0H compound	Al/PET tape	none	LS0H compound	57.9
	42	14 × 1.5 mm ²	Cu/round	EVA/ATH/ZnB	none	none	silane XLPO	62.5
	43	7 × 1.5 mm ²	Cu/round	LS0H compound	none	EPDM	XLPE	70.4
	44	19 × 1.5 mm ²	Cu/round	EVA/ATH/ZnB	none	none	silane XLPO	83.3
	45	24 × 1.5 mm ²	Cu/round	EVA/ATH/ZnB	none	none	silane XLPO	84.9
	46	10 × 2 × 2.8 mm	Cu/round	LS0H compound	Al/PET tape	none	mica tape+ LS0H compound	99.7
	47	19 × 1.5 mm ²	Cu/round	LS0H compound	none	LS0H compound	XLPE	106.6
	48	30 × 1.5 mm ²	Cu/round	EVA/ATH/ZnB	none	none	silane XLPO	108.7
	49	37 × 2.5 mm ²	Cu/round	LS0H compound	Al/PET tape	none	silane XLPO	112.0
	50	40 × 1.5 mm ²	Cu/round	LS0H compound	none	LS0H compound	XLPE	165.5
51	48 × 2 × 0.8 mm ²	Cu/round	LS0H compound	Al/PET tape	none	LS0H compound	266.4	
IV	52	1 × 300 mm ²	Al/round	PVC FR	none	none	XLPE	2.0
	53	1 × 300 mm ²	Al/round	LS0H compound	none	LS0H compound	XLPE	2.0

Group No.	Cable sample No.	Characteristics						
		Conductor Size	Conductor Material/Shape	Outer Sheath	Armour or Concentric Conductor	Bedding	Insulation	χ
IV	54	1 × 120 mm ²	Al/round	PVC FR	none	none	XLPE	2.9
	55	1 × 70 mm ²	Al/round	LS0H compound	none	LS0H compound	XLPE	3.7
	56	4 × 240 mm ²	Al/round	LS0H compound	none	LS0H compound	XLPE	5.5
	57	5 × 95 mm ²	Al/round	PVC FR	none	LS0H compound	XLPE	5.5
	58	5 × 185 mm ²	Al/round	PVC FR	none	LS0H compound	XLPE	6.8
	59	4 × 95 mm ²	Al/round	LS0H compound	none	LS0H compound	XLPE	9.6
	60	4 × 50 mm ²	Al/sector	PVC FR	Al wires	PVC	XLPE	10.2
	61	4 × 50 mm ²	Al/sector	PVC FR	Cu tape and wires	EPDM	XLPE	11.0
	62	5 × 50 mm ²	Al/round	PVC FR	none	LS0H compound	XLPE	12.6
	63	5 × 50 mm ²	Al/round	LS0H compound	none	LS0H compound	XLPE	12.6
	64	1 × 2 × 1.0 mm	Cu/round	PVC	none	none	PVC	23.1
	65	3 × 1.5 mm ²	Cu/round	EVA/ATH/ZnB	none	flame-retardant XLPE	mica tape+silane XLPO	26.4
	66	1 × 2 × 0.8 mm	Cu/round	PVC	Al/PET tape	none	PVC	27.5
	67	2 × 0.8 mm	Cu/round	LS0H compound	Al/PET tape	none	LS0H compound	28.2

Group No.	Cable sample No.	Characteristics						
		Conductor Size	Conductor Material/Shape	Outer Sheath	Armour or Concentric Conductor	Bedding	Insulation	χ
IV	68	2 × 0.8 mm	Al/round	LS0H compound	Al/PET tape	none	LS0H compound	28.2
	69	3 × 1.5 mm ²	Cu/round	PVC	none	EPDM	PVC	32.3
	70	3 × 1.5 mm ²	Cu/round	PVC	none	EPDM	XLPE	32.3
	71	3 × 1.5 mm ²	Cu/round	LS0H	none	EPDM	XLPE	40.6
	72	4 × 0.8 mm	Cu/round	LS0H compound	Al/PET tape	none	LS0H compound	41.4
	73	2 × 2 × 0.8 mm	Cu/round	PVC	none	none	PVC	51.8
V	74	3 × 240 mm ²	Cu/round	EVA/ATH/ZnB	Cu tape and wires	LS0H compound	mica+silane XLPO	4.3
	75	3 × 240 mm ²	Cu/round	EVA/ATH/ZnB	none	LS0H compound	silane XLPO	4.7
	76	4 × 35 mm ²	Cu/round	LS0H compound	galvanised steel wires	LS0H compound+ fireproof swelling tape	mica tape+ XLPE	8.0
	77	2 × 16 mm ²	Cu/round	thermoplastic LS0H	galvanized steel wires	LS0H compound	XLPE	8.1
	78	2 × 16 mm ²	Cu/round	thermoplastic LS0H	none	LS0H compound	XLPE	10.7
	79	4 × 35 mm ²	Cu/round	LS0H compound	galvanised steel wires	LS0H compound	mica tape+ XLPE	11.7

Group No.	Cable sample No.	Characteristics						
		Conductor Size	Conductor Material/Shape	Outer Sheath	Armour or Concentric Conductor	Bedding	Insulation	χ
V	80	4 × 25 mm ²	Cu/round	LS0H compound	none	LS0H compound	XLPE	15.6
	81	4 × 35 mm ²	Cu/sector	LS0H compound	Cu tape, foil and wires	LS0H tape	mica tape+ XLPE	17.5
	82	4 × 35 mm ²	Cu/sector	LS0H compound	Cu tape and wires	LS0H tape	mica tape+ XLPE	17.7
	83	3 × 1.5 mm ²	Cu/round	EVA/ATH/ZnB	Cu tape and wires	flame-retardant XLPE	silane XLPO	19.9
	84	3 × 1.5 mm ²	Cu/round	EVA/ATH/ZnB	none	none	silane+LPO	26.4
	85	5 × 1.5 mm ²	Cu/round	LS0H compound	Cu tape, foil and wires	LS0H tape	mica tape+ XLPE	38.9
	86	5 × 1.5 mm ²	Cu/round	LS0H compound	Cu tape and wires	LS0H tape	mica tape+ XLPE	44.4
	87	5 × 1.5 mm ²	Cu/round	LS0H compound	none	LS0H compound	XLPE	46.6
	88	30 × 1.5 mm ²	Cu/round	EVA/ATH/ZnB	Cu tape and wires	LS0H compound	mica+ silane XLPO	99.9
	89	30 × 1.5 mm ²	Cu/round	EVA/ATH/ZnB	none	LS0H compound	silane XLPO	108.7

Those cables were constructed with the same materials. Six fire-resistant power and control non-halogenated cables of various constructions (Tab. 2), with the same type of conductor, sheath and insulation were studied experimentally. A schematic view of the three-conductor cable is shown in Figs 12 and 13.

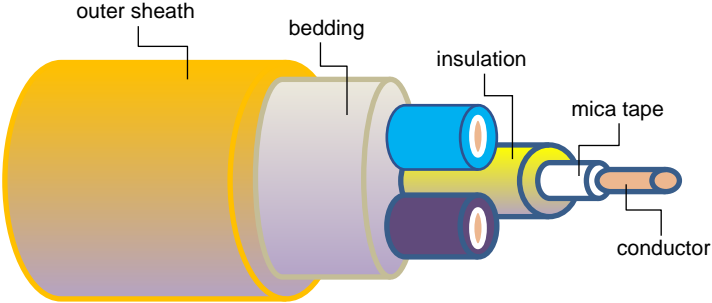

Fig. 4. Schematic of three-conductor cable sample

These cables were chosen as typical examples of electric cables used in buildings for a series of tests performed by means of three experimental methods described in chapter 6.

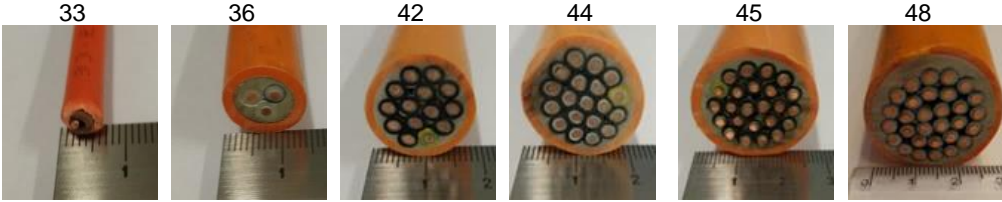

Fig. 5. View of cross-section of cables

Each tested cable was constructed of copper, solid, round conductors (class 1) and primary mica tape conductor insulations. The main insulation was formed of cross-linked polyolefin (XPLO) compounds, the bedding (except in the case of the single conductor cable) was made of flame-retardant XLPE, and the outer sheath was based on ethylene/vinyl/acetate (EVA) copolymer filled with ATH and ZnB as a flame retardant.

For the investigation of fire effluent toxicity properties, a single PVC-insulated non-sheathed copper wire (external diameter of approximately 3.0 mm, diameter of conductor 1.36 mm, and weight of cable 21 kg/km) was tested.

6. EXPERIMENTAL METHODS

6.1. Large-scale cable experiments

The test method described in the EN 50399 standard (Fig. 14) was chosen for the full-scale experiments because the cables are tested in their real-life configurations (cable trays) as a whole product, such as the ones installed in buildings.



Fig. 6. External view of EN 50399 standard test chamber at the accredited ITB Fire Testing Laboratory in Pionki, Poland

The EN 50399 test method was developed during the FIPEC project [23] and it is based on the test method described in the IEC 60332-3 specification, supplemented with the oxygen consumption calorimetry method for determining heat and smoke release rates [23,157]. Cable specimens of a size about 3.6 +/-0.1 m (height) x 300 mm (width) were ignited from the front side by the burner; initially, most heat was emitted from the front side of a specimen [158]. CO₂ concentration was measured using non-dispersive infrared (NDIR) spectrometers, and oxygen depletion by a paramagnetic analyser. This allows to obtain accurate HRR

results for materials of unknown composition, i.e. as the amount of heat release per unit mass of O₂ consumed or per unit mass of CO₂ produced, which is relatively constant for a large number of materials [159].

The NDIR analytical method is based on the same particle characteristics (vibrations) as the FTIR described further in section 4.2.2. CO₂ detection is a fire gas diffusing through a metal frit, which is part of the sensor. Polychromatic light from incandescent bulbs passes through the gas sample and is absorbed in proportion to the amount of CO₂ present. The reflection of light off the internal walls increases the path length, thus increasing sensitivity. The filter in front of the detector allows a band of wavelength centre at 4.26 μm, corresponding to CO₂ [160].

A single test of each cable was performed according to EN 50399, but during each experiment the specimen consisted of several pieces of cable (the exact number depended on cable diameter, as the specimen width was constant and not exceeding 300 mm). In conclusion, several pieces of each cable were studied during a single experiment.

Cable specimens were tested inside the chamber, in their end-use application as cable trays mounted on a 4 m long ladder – Figs 15 a) and b). The nominal HRR level of 20.5 kW, airflow rate through the chamber of (8000 ±800) l/min and a white light detector were used in the burner [4].

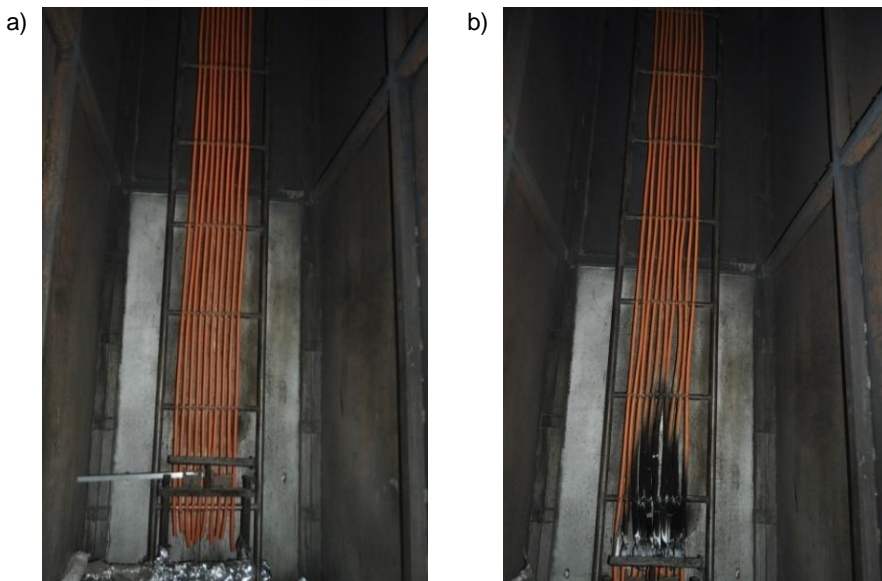

*Fig. 7. Cable sample No. 44 installed on the test ladder
a) before the test, b) after the test at the accredited ITB Fire Testing Laboratory
in Pionki, Poland*

6.2. Small-scale cable experiments

6.2.1. Introduction

Similarities in the main construction parts of cables, e.g. outer sheaths, beddings and conductor insulations, were assessed by TGA in a nitrogen atmosphere supplemented with FTIR spectrometry. A small specimen of each polymeric material was required for both analytical tests.

6.2.2. Thermo-Gravimetric analysis (TGA)

Thermogravimetry is a thermal analysis technique, which allows to investigate the change in weight for a material as a function of time or temperature. TGA is mainly used for understanding certain thermal events, such as absorption, adsorption, desorption, vaporisation, sublimation, decomposition, oxidation and reduction by weight change profile analysis, which is recorded when the specimen is subjected to a heating or cooling environment in a controlled manner. In addition, TGA can be utilised for the kinetics of the reaction evaluation and the determination of volatile or gaseous products lost during such chemical reactions for samples as nanomaterials, polymers, polymer nanocomposites, paints, coatings and non-metallic elements of cables [161, 162].

The TGA apparatus consisted of an electronic microbalance, specimen holder (crucible), furnace, thermocouple, temperature programmer and recorder. The microbalance was calibrated once per testing period using 100 μg and 1000 μg . The thermocouple was calibrated on reference metals, such as nickel (Ni) and its alloys, with known Curie temperatures, above which the material loses its ferroelectric and piezoelectric behaviour. The Curie point for one of the reference metals (Ni) was equal to $356.99^\circ\text{C} + / - 0.44^\circ\text{C}$.

For the TGA (Fig. 16) analysis, the weight of the load material did not exceed 90 mg. A chemically and thermally neutral alumina and platinum pan was used for transportation of the specimen into a furnace, and a $50^\circ\text{C}/\text{min}$ heating rate up to $1,000^\circ\text{C}$ was applied for the decomposition processes. The high heating rate was chosen to reflect the heating rate observed in fire conditions [163].

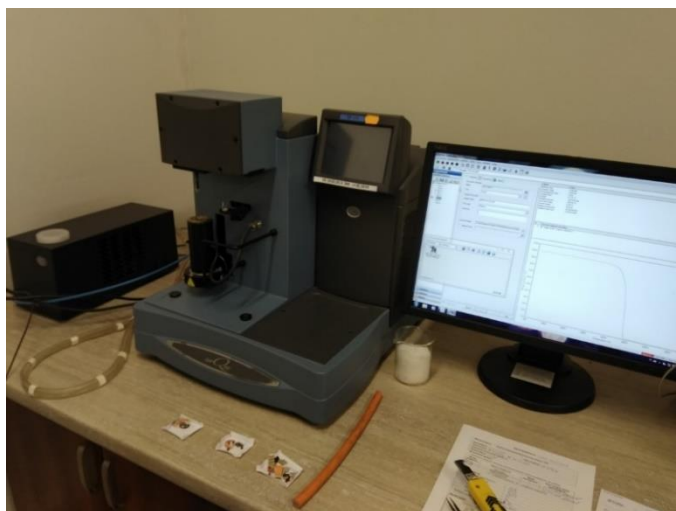

Fig. 16. General view of the TGA analyser at the accredited ITB Fire Testing Laboratory in Pionki, Poland

6.2.3. FTIR spectrometry for solids and gas analysis

The FTIR spectroscopy was chosen as an accurate analytical technique for the identification of substances, and the detection and quantification of fire gases. Most molecules absorb infrared radiation, causing changes in their internal vibration (bend, stretch or twist). The amount of infrared light absorbed is proportional to the concentration of the absorbing species. The energy is converted to kinetic energy, causing the molecules to speed up and, thus, heat the gas. A popular infrared light source is an incandescent household bulb. Each molecule absorbs infrared light at wavelengths representative of the types of bonds present.

The FTIR spectrometer produces a beam of infrared irradiation, which is emitted from a glowing black-body source and passes through into an interferometer, where spectral encoding takes place. The recombination of beams with different path lengths in the interferometer creates constructive and destructive interference called an interferogram. Then, the tested specimen absorbs specific frequencies of energy, which are uniquely characteristic of the sample from the interferogram. The detector measures the special interferogram signal in energy as a function of time for all frequencies simultaneously. In the meantime, a beam is superimposed to provide a reference (background) for the instrument operation. Finally, the desirable spectrum is obtained after the interferogram automatically subtracts the spectrum of the background from the sample spectrum using Fourier transformation computer software [164].

In short, the infrared spectrum obtained from the FTIR spectrometer is placed in the mid-infrared region of 2.5 – 15 μm between 4000 and 666 cm^{-1} . Transition energies corresponding to changes in vibrational energy state for many functional groups are located in the region (4000 – 400 cm^{-1}) and, hence, the appearance of an absorption band in this region can be used to determine whether specific functional groups exist within the molecule [164]. For instance, CO_2 has a strong absorbance at 4.26 μm (wave length 2350 cm^{-1}), and C-H bonds absorb in the range of 3.3 – 3.5 μm (wave length 2800 – 3000 cm^{-1}), depending on the structure of the rest of the molecule [123, 160].

The Attenuated Total Reflectance (ATR) method for FTIR spectrometry analysis (Fig. 17) was used for a qualitative analysis of outer sheaths, beddings and the insulation of electric cables. This method is characterised by high speed of measurement and the small amount of material necessary for testing [165].



Fig. 8. Photo of the FTIR spectrometer at the accredited ITB Fire Testing Laboratory in Pionki, Poland

In the ATR-FTIR method, an internal reflection element (crystal) with a high refractive index is used which directs the beam to the sample. Then, an evanescent wave is created, which passes through the specimen. The angle of the incident IR beam should exceed the critical angle to achieve total internal reflection; otherwise, the resulting spectrum will be a combination of ATR and external refraction [166].

Cable sheaths, beddings and insulations were tested on a diamond crystal and 16 scans per specimen were applied. The top layer of each tested material was scrapped and washed in acetone prior to the analysis to avoid interference caused by grease and other dirt particles on the specimen surfaces.

The toxic components from fire gases are difficult to determine because reactions are often temperature dependent and the environment is hot. Also, a lot of soot is produced during the combustion processes. Due to the different properties of the gas components, a different time-consuming procedure for each species was used. FTIR spectrometers, as a continuous monitoring technique, overcome many of the problems in smoke gas analyses. FTIR offers an opportunity to set up a calibration and prediction method for each gas showing a characteristic spectral band in the infrared region of the spectrum [165].

The use of FTIR allows the analysis of the following combustion gases: CO, CO₂, COCl₂ (phosgene), COF₂, HBr, HCl, HCN, HF, NO, NO₂, SO₂, CH₄ (methane), C₂H₂ (acetylene), C₂H₄ (ethylene), C₂H₆ (ethane), H₂O etc. The spectra for these gases are displayed to scale in Fig. 18 [165, 167].

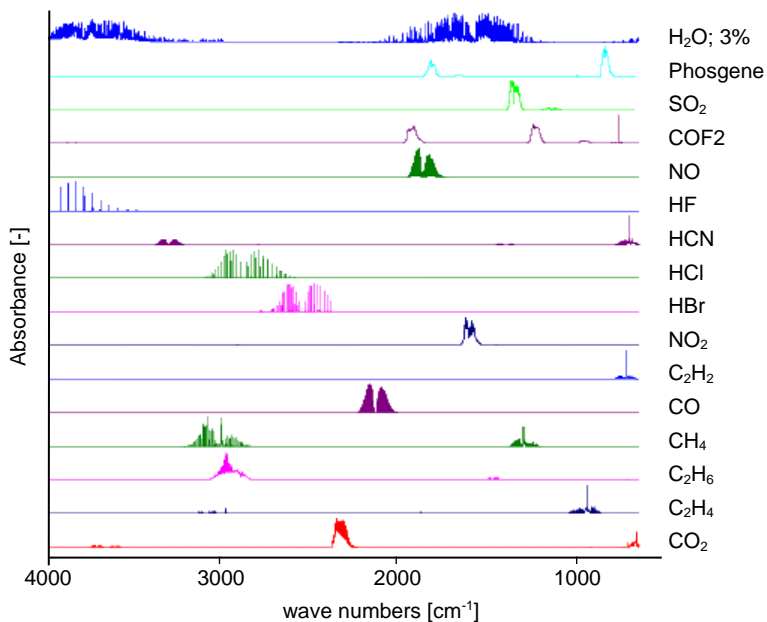

Fig. 9. FTIR spectra for 16 combustion gases [167]

The sampling system is heated to approximately 170°C to prevent absorption losses of water-soluble gases on moist surfaces. The system

contains a calibration gas generation system for chemicals that are liquid at room temperature, and allows for the addition of water to dry calibration gas standards, for method validation [167]. A schematic diagram for an optimised FTIR apparatus sampling system is shown in Fig. 19.

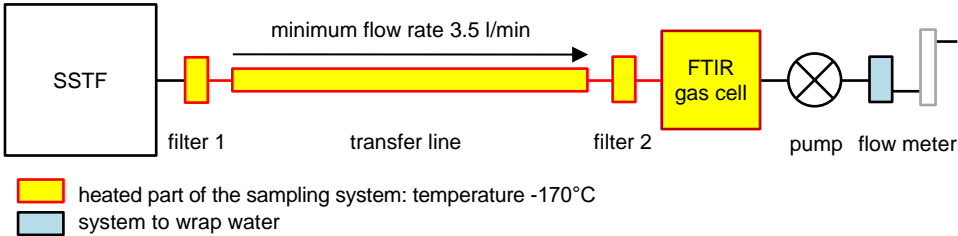

Fig. 10. Diagram of optimised sampling system [167]

6.2.4. Cone calorimeter apparatus

The cone calorimeter method [168] – Figs 20 a) and b) was used for relatively low cable specimen testing under different heat fluxes.

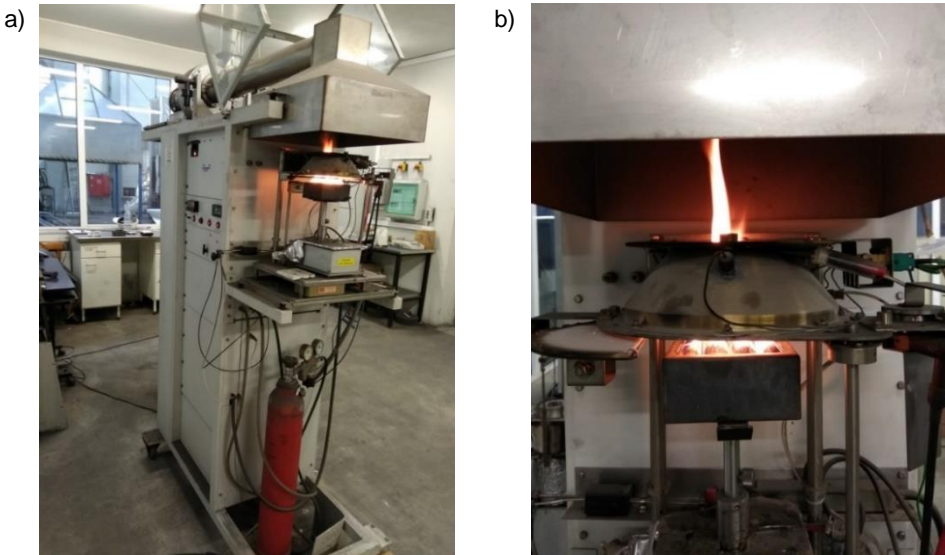
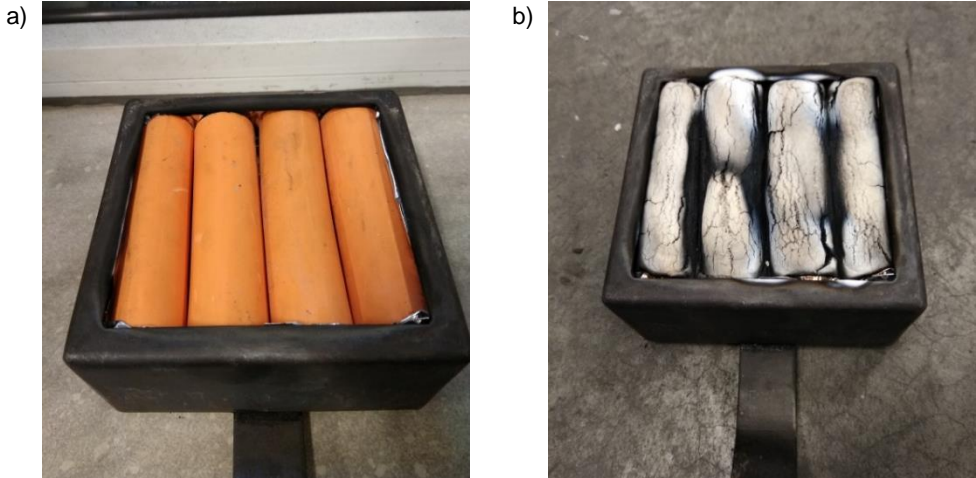

Fig. 20. Cone calorimeter
 a) external view of test apparatus, b) cable specimen during the test
 at the ITB Fire Testing Laboratory in Pionki, Poland

The cone calorimeter method is a small-scale laboratory method that considers the measurement of the HRR during the burning process of

materials. Determining the HRR using this method consists in measuring the loss of oxygen as a fuel in the combustion process [169].

Specimens of a size of 0.1 m × 0.1 m (Fig. 21) were placed in a specially adapted holder on a calibrated and tared balance.



*Fig. 21. Cable specimen for cone calorimeter testing
a) specimen before the test, b) specimen after the test*

For the PVC cable specimens, a steel grid (Fig. 22) was used to avoid weight error after swelling the specimen.



Fig. 22. PVC cable specimen secured by steel grid

6.2.5. Steady-State Tube Furnace (Purser Furnace) for fire effluent toxicity tests

Fire effluent toxicity must be determined as a function of the material and the fire conditions, particularly temperature and oxygen availability in the fire zone. The acceptable agreement with large-scale test data over the range of fire conditions points to the Steady-State Tube Furnace, which allows for the relationship between ϕ and the toxic product yields [170]. In order to examine the dependence of the amount of combustion gases obtained during ventilation-controlled conditions, the Steady-State Tube (Purser) furnace developed by Purser et al. [171] was used (Fig. 23) [121].

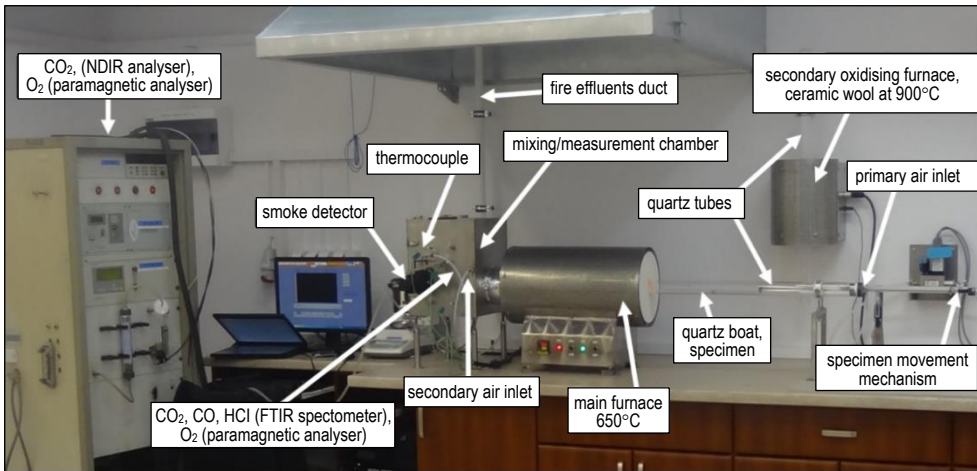

Fig. 23. Steady-State tube (Purser) furnace at the ITB Fire Laboratory in Pionki, Poland

During the experiment, the amount of primary air (fuel) can be changed to receive different fire ventilation conditions, from low-ventilated room fires to well-ventilated flaming.

The specimens were placed in a quartz boat and moved mechanically into the furnace (Fig. 23). The feed rate (mass load rate) of the specimen should be about 1 g/min, calculated according to the appropriate mass load rate and speed of movement mechanism. For cables, which were tested as a whole, it is almost impossible to reach the standard feed rate.

During the thermal decomposition of the material, fire effluent gases were produced and moved into the mixing/measurement chamber. They then passed through the non-dispersive infrared (NDIR) sensors (CO₂), paramagnetic analyser (O₂) and FTIR spectrometer equipped with a gas

cell for the analysis of CO₂, CO and HCl. Parts of the fire effluents were passed through the secondary furnace in order to determine the amount of light HCs after the complete oxidation to CO₂.

Concentrations of HCs were calculated as a difference between the CO₂ obtained from the secondary furnace and the CO₂ (as a product of complete oxidation) and CO concentrations directly from the mixing chamber. The secondary CO₂ and O₂ concentrations were measured using NDIR sensors. The path length during the FTIR measurements was set at 4 m. Regions with the following wavenumbers were selected for analysis: 754.99 – 743.06 cm⁻¹ (CO₂), 2005.00 – 2025.00 cm⁻¹ (CO) and 2699.19 – 2705.46 cm⁻¹ (HCl). The yields of combustion gases were calculated according to the ISO 19700 [121] specification.

7. FIRE PROPERTIES OF STUDIED CABLES

The fire behaviour of various products is characterised by a number of standard parameters, such as peakHRR, THR, FS, peakSPR, TSP, flaming droplets and particles, and toxic product yields as measured in standardised conditions. Determining the HRR using the calorimetric method involves the measuring of the loss of oxygen as a fuel in the combustion process. The mass flow and oxygen concentration in the extraction system allows to estimate continuously the amount of heat released [172].

The following parameters and observations have been registered during each large-scale cable experiment:

- heat production: HRR, THR,
- smoke emission: SPR, TSP,
- presence of burning droplets,
- range of flame spread FS.

THR_{1200s} (MJ) is the total heat release from the specimen in the first 1200 s of exposure to the main (primary) burner flames, and TSP_{1200s} (m²) is the total smoke production from the specimen in the first 1200 s of exposure to the main (primary) burner flames.

In order to evaluate electric cables, which are installed on walls, ceilings or floorings in terms of fire, the criteria [17] are suitable to express the fire behaviour of cables as building products.

When non-metallic (combustible) materials undergo thermal decomposition, toxic products are generated. The most commonly occurring of these are CO [173, 174], CO₂, various saturated and unsaturated HCs, HCl (for PVC-insulated or sheathed cables) and oxygen depletion. CO₂ and oxygen depletion cause hyperventilation, HCl and HCs are irritating for the lungs, and CO is highly toxic when in high concentrations. The amount of these species varies with changes in ventilation conditions during the combustion process. The ventilation conditions are characterised by the equivalence ratio ϕ (1), which is based on the oxygen requirement for the “stoichiometric” combustion to CO₂ and water [31].

It is well known that insulated wires and cables are widely used in residential buildings, typically flush-mounted, but also as flexible connections for electrical equipment to the mains. These cables may be easily ignited by a short circuit in the installation or burnt from other burning

items. Flame spread along the cable causes the release of fire effluents, mostly in toxic fire cases. Atmospheric oxygen is needed to sustain the flame, but, even under pyrolysis, toxic fumes are produced. This phenomenon has prompted the need to investigate fire effluent toxicity at the most typical ventilation scenarios.

From a legal and ethical point of view, fire effluent toxicity cannot be assessed directly by exposing humans or animals to fire effluents. It is measured indirectly using various laboratory methods. The parameters which describe fire effluent toxicity are: concentration, yield, toxicity index, lethal concentration (LC₅₀) (Tab. 3), concentration of irritant gases (IC₅₀), Fractional Effective Concentration (FEC) and Fractional Effective Dose (FED).

Table 3. LC₅₀ values for narcotic gases, oxygen depletion and irritants, including most important organic irritants [123]

Type of toxicant	Fire effluent gas	LC ₅₀ values (ISO 13344)	Unit
Narcotics	O ₂	5.4	%
	CO ₂	-	-
	CO	5700	ppm
	HCN	165	ppm
Irritants	HF	2900	ppm
	HCl	3800	ppm
	HBr	3800	ppm
	NO _x	170	ppm
	SO ₂	1400	ppm
	Formaldehyde	750	ppm
	Acrolein	150	ppm

The yield of fire gases and the FED factor tend to be the most adequate to predict the toxic potency of fire effluents from different types of materials. Yields are expressed as a mass of chemical compound determined from the fire effluent in grams to the total mass loss of the sample in grams.

The FED factor is defined as the ratio of the exposure dose for an asphyxiant toxicant to that exposure dose of the asphyxiant expected to produce a specified effect on an exposed subject of average susceptibility. It may refer to any effect, including incapacitation, lethality or even other endpoints. If equal to one, it indicates that the sum of concentration

of individual species will be lethal to 50% of the population over a 30 min exposure [26, 123, 175].

Eighty-three cables (eighty-nine cables samples) of various designs and materials were analysed to explain the relationship between the constructional-material parameters and fire properties of typical cables used in buildings. All cables have been tested by means of large-scale cable test methods, as described in chapter 5.1.

The cables were divided into five groups as shown on Fig. 9 on the basis of their constructional and material parameters, which were developed during the investigation of the nature of factors affecting the fire properties of electric cables listed on Fig. 10. The following number of cable samples were examined:

I. The material of conductor (copper or aluminium) – 14 cable samples.

II. The shape of the conductors' cross-section (round or sector-shape) – 14 cable samples.

III. Number of conductors belonging to eight different cable families varying in general construction and materials – 23 cable samples.

IV. The non-metallic elements (outer sheaths and/or insulations) – 22 cable samples (including five PVC-based cables, seven flame-retardant PVC cables (PVC-FR), and twelve LSOH cables of mostly unknown composition).

V. The presence of concentric barrier – 16 cable samples (galvanised steel wires or copper concentric conductors (tape and wires) or aluminium wires; in two cases, copper foil was additionally used under the outer sheath and, in one case, fireproof swelling tape).

Thirteen out of eighty-three cables were constructed from flame-retardant PVC (cable samples Nos. 17 – 20, 23, 27, 52, 54, 57, 58, 60 – 62), and eleven of the chosen cable samples were constructed with a single conductor of different size (cross-sectional area) – cable samples Nos. 1, 2, 30, 32, 33, 35, 38, 52 – 55.

The summary chart (Fig. 24) shows that there is no clear relationship between the fire parameters and cable parameter χ . Relatively low values of fire parameters were obtained for cables with values of cable parameter χ below 26.41, which is in good agreement with the results obtained for other sets of cables within large-scale projects, such as FIPEC [25, 176, 198] and CEMAC [199]. The exception was the single conductor non-halogenated cable sample No. 33), which did not have bedding included in its construction, and resulted in higher fire parameters than those received for multi-conductor cables of the same construction and materials ($\chi = 15.8$).

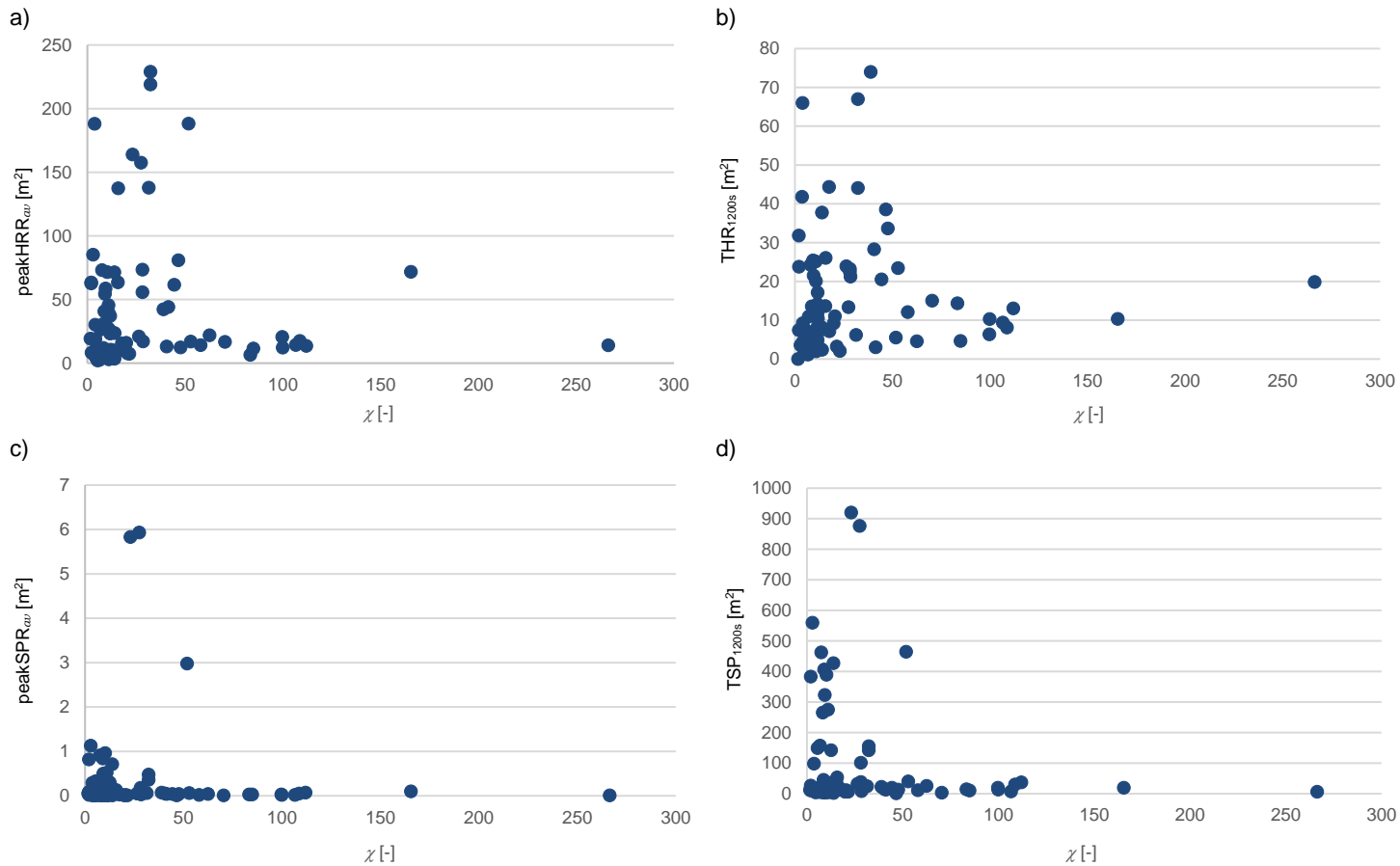

Fig. 24. Summary of experimental measurements as a function of cable parameter χ
 a) $\text{peakHRR}_{\text{ave}}$, b) $\text{THR}_{1200\text{s}}$, c) $\text{peakSPR}_{\text{ave}}$, d) $\text{TSP}_{1200\text{s}}$

The maximum values of peakHRR_{av} , THR_{1200s} , peakSPR_{av} and TSP_{1200s} were obtained for cable samples No. 69 and 70, but the highest level of each parameter ($\text{peakHRR}_{av} = 229 \text{ kW}$, $\text{THR}_{1200s} = 67 \text{ MJ}$, $\text{TSP}_{1200s} = 155 \text{ m}^2$ and $\text{peakSPR}_{av} = 0.48 \text{ m}^2/\text{s}$) was obtained for cable sample No. 69 consisting of PVC-based outer sheath and insulations and non-vulcanised EPDM as a bedding (Tab. 2), even if the highest value of cable parameter χ (equal to 40.6) was calculated for unarmoured non-halogenated cable No. 71 (Tab. 2). Lower values of fire parameters were obtained for non-halogenated cables with various construction parameters rather than for halogenated cables. A discussion of this behaviour is provided below in section 8.1.4.

The number of tests performed showed that the highest heat release (peakHRR_{av} , THR_{1200s}) – Figs 25 a) and b) and smoke generation parameters (peakSPR_{av} and TSP_{1200s}) – Figs 26 a) and b) were obtained for non-flame retardant PVC-based cables. Those cables were burned completely, as evidenced by the $\text{FS} = 3.5 \text{ m}$ (Fig. 27).

It can be seen that for flame-retardant PVC cables (FR-PVC-based cables from parameter groups II and IV) heat parameters decreased to peakHRR_{av} values more than 50 kW, and THR_{1200s} more than 20 MJ. The decreased values of heat release parameters were obtained for flame-retardant PVC-based cables, which consist of four and five conductors (parameter group IV), and were even ten times lower than for single-conductor cables of the same construction materials and cross-sections of the conductors.

In Fig. 25a), in group II there are two diverging points related to the peakHRR_{av} and THR_{1200s} parameters for single-conductor cables, whose cross-sectional area of round conductors is 1.5 mm^2 , i.e. relatively small. This phenomenon can be explained by the relatively large cable parameter calculated for the entire cable sample with a small outer diameter and lack of a barrier in the form of armour and bedding, which also caused high flame spread ($\text{FS} = 3.5 \text{ m}$) along each cable (Fig. 27). The use of halogen-free materials in the above-mentioned cables, however, has resulted in very low values of smoke release parameters – Figs 26 a) and b).

The highest values of TSP_{1200s} and peakSPR_{av} parameters were obtained for cables consisting of non-flame retardant PVC outer sheath and insulation, with peakSPR_{av} equal to $5.93 \text{ m}^2/\text{s}$ and TSP_{1200s} equal to 920 m^2 . This phenomenon is caused by the dehydrochlorination reaction and thus, initiated chain scission followed by cyclisation reactions within the polyene chain, which consequently increases the concentration of volatile unsaturated and aromatic HCs. Their presence causes increased smoke

density and, as a consequence, poor visibility in a fire. The mechanism of this process is discussed in chapter 8.1.4.

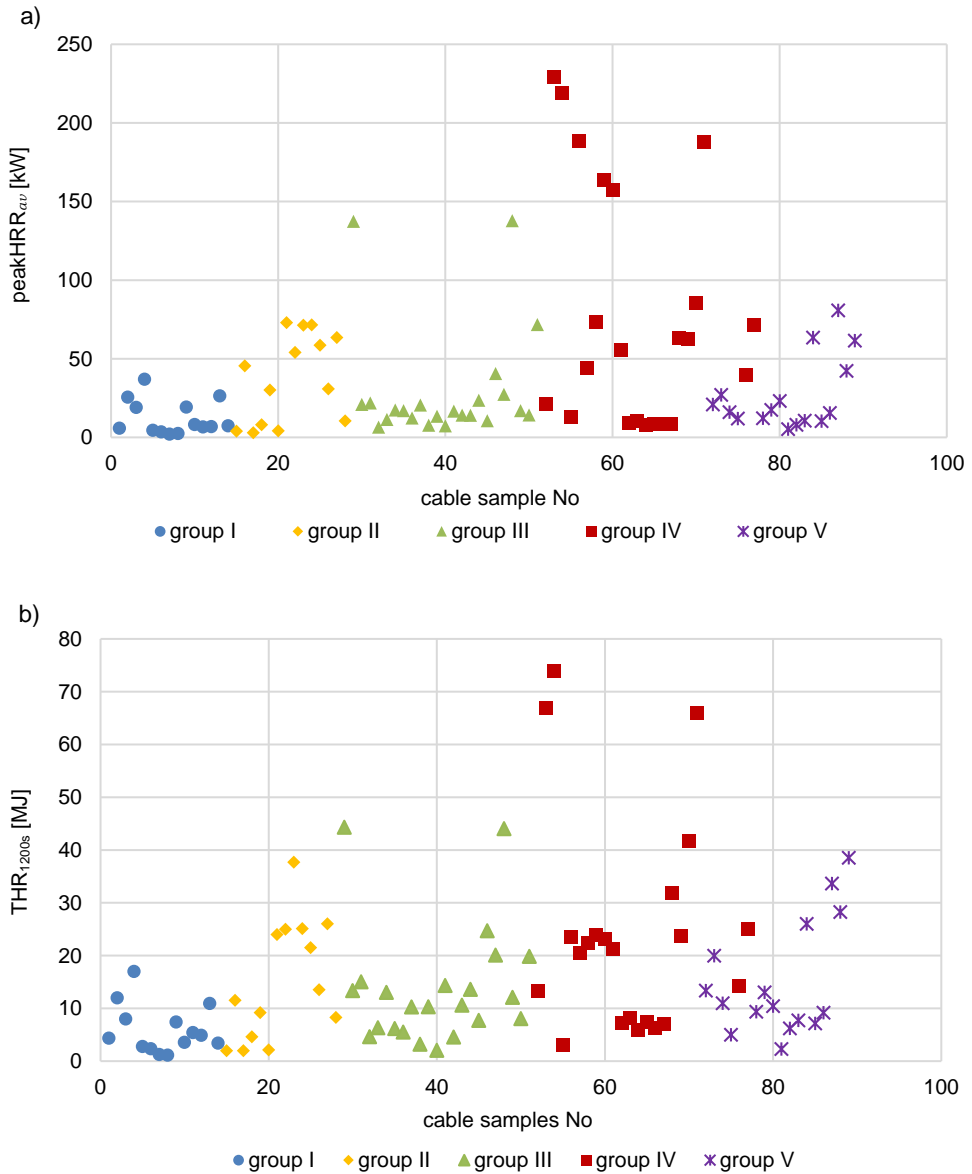

Fig. 25. Heat release results for 89 cable samples
a) peakHRR_{av}, b) THR_{1200s}

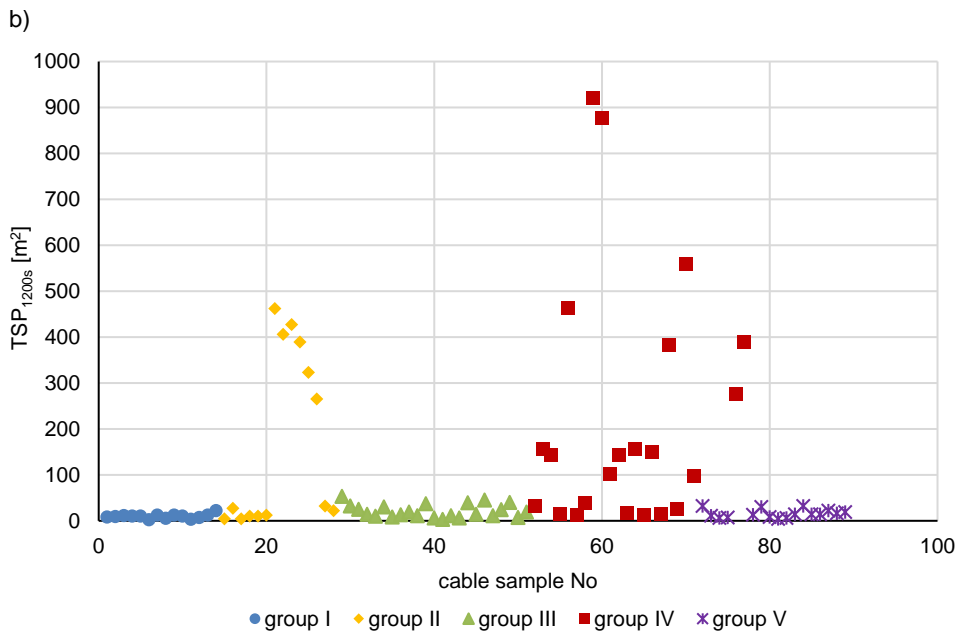
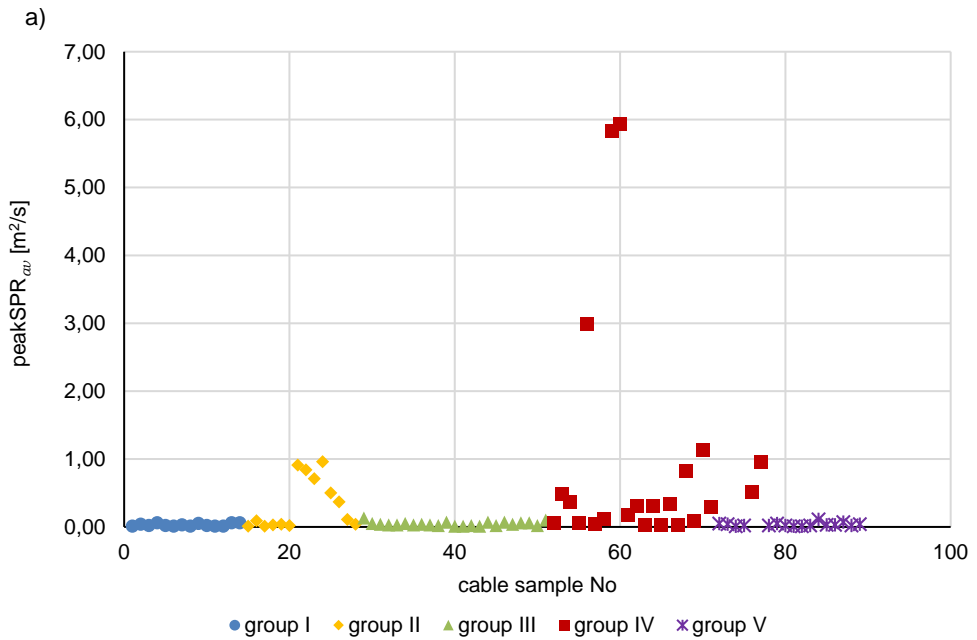

Fig. 26. Smoke generation results for 89 cable samples
 a) peakSPR_{av}, b) TSP_{1200s}

The addition of a flame retardant to plasticised PVC caused six times lower values of the parameters related to the smoke release rate, and more than two times lower in the case of total smoke production than for non-flame retardant PVC.

The smoke generation results obtained for LS0H cables are low in each case, which is due to the occurrence of about 30–40% of inorganic fillers, which act as flame-retardants and smoke suppressants.

A significant fire parameter in the case of cable fires is the FS over the entire building. The FS results (Fig. 27) show an ambiguous tendency. In most cases, the cables that have been damaged along their entire length are cables made of non-metallic materials based on PVC and single-conductor cables, which is demonstrated in chapters 8.1.3 and 8.1.4.

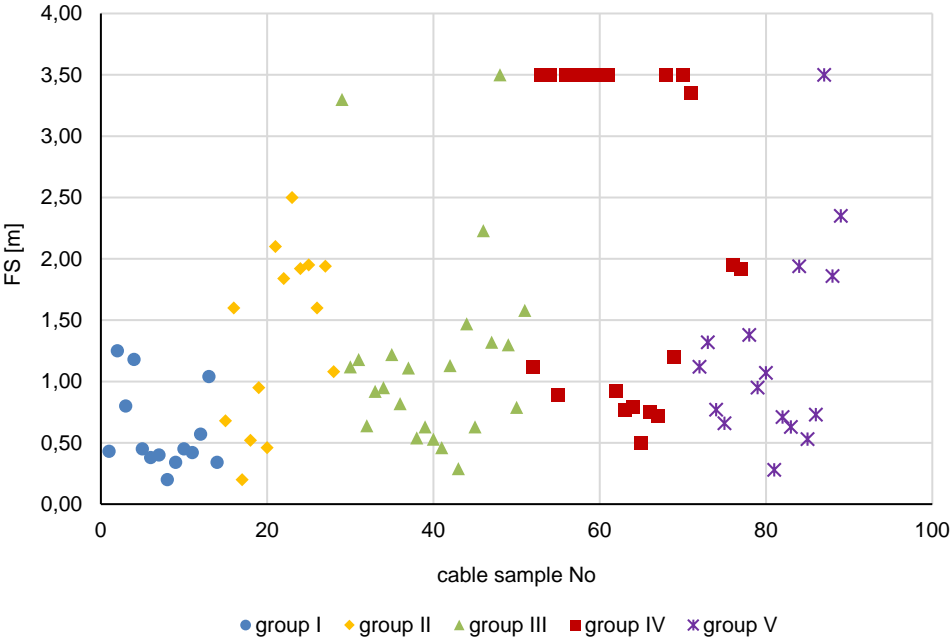

Fig. 27. Smoke generation results for 89 studied cable samples

Also noteworthy is the last group of cables (in parameter group V). Lack of concise packing of insulated conductors in cables, caused by lack of bedding, induced the so-called “candle phenomenon”. The flame penetrated the outer sheath, thin concentric conductor (0.4 mm copper wires, 0.1 mm thick copper tape and 0.1 mm thick copper foil for BFSI-EMC cables). They were subjected to heat and oxidation and, as a con-

sequence, the flame reached the internal parts of the cable, i.e. thin insulation. Continuous burning of the cables also caused a slight increase in other parameters related to heat release for these cables (Fig. 25).

The results confirmed that the use of PVC as sheaths and insulation, as well as lack of bedding in the construction, caused significant increase in the length of damage over the cables, which as a consequence increased the FS.

The test performed on a large number of cables showed that the parameters related to the type of material used for conductor formulation are less important in the case of the fire properties of electric cables, while the most significant constructional-material parameter from the point of view of the fire safety of buildings is the parameter related to the type of insulation and sheathing material used. Also, the use of single-conductor cables with small diameters has a negative effect on the fire properties of cables, which is associated with lack of metallic barriers in the cable, and lack of armours and bedding in the cable construction.

8. ANALYSIS OF THE RELATIONSHIP BETWEEN CONSTRUCTIONAL–MATERIAL PARAMETERS AND THE FIRE PROPERTIES OF ELECTRIC CABLES

8.1. Tests results and discussion for a large number of cables of various construction

8.1.1. Introduction

Single tests according to the EN 50399 standard were performed for each cable sample, and the following heat and smoke release parameters were measured for the tested cables: peakHRR_{av}, THR_{1200s}, TSP_{1200s}, peakSPR_{av} and FS. These are presented in separate chapters in order to select the constructional–material parameters of the cables. The test results (Tab. 4) have been analysed for five aspects according to Fig. 9.

8.1.2. Summary results for analysis

The analysis of the influence of construction and material parameters was carried out on selected cable samples. Cable samples were selected by considering only one parameter by which these cables differ. Some cables in groups differed slightly in the cross-section of non-combustible conductors, which does not affect the analysis performed because the slight differences in cross-sectional area of conductors do not significantly influence the combustion process.

Table 4. Summary results for tested cable samples according to constructional–material parameters

Group No.	Cable sample No.	peakHRR _{av} [kW]	THR _{1200s} [MJ]	peakSPR _{av} [m ² /s]	TSP _{1200s} [m ²]	FS [m]
I	1	19	7	0.05	12	0.34
	2	8	4	0.02	10	0.45
	3	6	4	0.01	8	0.43
	4	19	8	0.02	11	0.8
	5	2	1	0.03	12	0.4
	6	2	1	0.01	5	0.2

Group No.	Cable sample No.	peakHRR _{av} [kW]	THR _{1200s} [MJ]	peakSPR _{av} [m ² /s]	TSP _{1200s} [m ²]	FS [m]
I	7	26	11	0.06	12	1.04
	8	7	3	0.06	22	0.34
	9	7	5	0.01	3	0.42
	10	7	5	0.01	7	0.57
	11	26	12	0.04	9	1.25
	12	37	17	0.06	10	1.18
	13	5	3	0.02	10	0.45
	14	3	2	0.01	2	0.38
II	15	30	9	0.04	10	0.95
	16	4	2	0.01	4	0.68
	17	54	25	0.84	406	1.84
	18	31	14	0.37	265	1.6
	19	73	24	0.91	462	2.1
	20	59	22	0.5	323	1.95
	21	8	5	0.03	10	0.52
	22	4	2	0.02	12	0.46
	23	72	25	0.96	389	1.92
	24	46	12	0.09	27	1.6
	25	3	2	0.01	4	0.2
	26	11	8	0.04	22	1.08
	27	71	38	0.71	427	2.5
	28	63	26	0.11	32	1.94
III	29	11	8	0.02	14	0.63
	30	41	25	0.07	45	2.23
	31	27	20	0.04	11	1.32
	32	24	14	0.07	39	1.47
	33	137	44	0.13	53	3.3
	34	8	3	0.02	11	0.54
	35	7	2	0.01	6	0.53

Group No.	Cable sample No.	peakHRR _{av} [kW]	THR _{1200s} [MJ]	peakSPR _{av} [m ² /s]	TSP _{1200s} [m ²]	FS [m]
III	36	21	13	0.05	32	1.12
	37	17	6	0.03	8	1.22
	38	138	44	0.06	24	3.5
	39	12	6	0.04	13	0.82
	40	17	12	0.06	40	1.3
	41	14	5	0.02	11	1.13
	42	22	15	0.04	25	1.18
	43	17	14	0.01	3	0.46
	44	7	5	0.03	14	0.64
	45	11	6	0.03	10	0.92
	46	21	10	0.03	19	1.11
	47	14	8	0.02	7	0.79
	48	17	13	0.05	30	0.95
	49	13	10	0.07	37	0.63
	50	72	20	0.1	19	1.58
	51	14	11	0.01	6	0.29
IV	52	63	32	0.82	383	3.5
	53	63	24	0.09	26	1.2
	54	85	42	1.13	559	3.5
	55	188	66	0.29	98	3.35
	56	9	7	0.03	12	0.5
	57	8	6	0.33	149	0.75
	58	8	6	0.3	157	0.79
	59	9	7	0.03	15	0.72
	60	72	25	0.96	389	1.92
	61	39	14	0.52	275	1.95
	62	9	7	0.3	142	0.92
	63	10	8	0.03	16	0.77
	64	164	24	5.83	920	3.5

Group No.	Cable sample No.	peakHRR _{av} [kW]	THR _{1200s} [MJ]	peakSPR _{av} [m ² /s]	TSP _{1200s} [m ²]	FS [m]
IV	65	21	13	0.05	32	1.12
	66	158	23	5.93	876	3.5
	67	73	22	0.12	38	3.5
	68	56	21	0.18	101	3.5
	69	229	67	0.48	155	3.5
	70	219	74	0.36	142	3.5
	71	13	3	0.05	14	0.89
	72	44	21	0.04	13	3.5
	73	188	23	2.98	464	3.5
V	74	11	8	0.02	14	0.63
	75	8	6	0.01	6	0.71
	76	5	2	0.01	4	0.28
	77	12	5	0.02	7	0.66
	78	27	20	0.04	11	1.32
	79	23	10	0.02	8	1.07
	80	63	26	0.11	32	1.94
	81	10	7	0.03	14	0.53
	82	16	9	0.03	14	0.73
	83	16	11	0.01	6	0.77
	84	21	13	0.05	32	1.12
	85	42	28	0.02	16	1.86
	86	62	39	0.04	19	2.35
	87	81	34	0.07	22	3.5
	88	12	9	0.02	13	1.38
	89	17	13	0.05	30	0.95

8.1.3. Material used for conductor construction

Cable samples Nos. 1–14 (Tab. 2) were non-halogenated cables and differ only in the material used for the conductor construction.

The occurrence of aluminium conductors causes an increasing tendency in the case of peakHRR_{av} and THR_{1200s} (Fig. 28). In the case of cable samples Nos. 1, 4, 5, 7, 9, 12 and 13 with aluminium conductors, higher values of heat parameters were obtained than for corresponding cables with copper conductors (Nos. 2, 3, 6, 8, 10, 11 and 14 in Fig. 28), up to four times higher in the case of peakHRR_{av} for cable sample No. 7 in relation to peakHRR_{av} for cable sample No. 8 and three times higher for cable sample No. 4 in correspondence with cable sample No. 3.

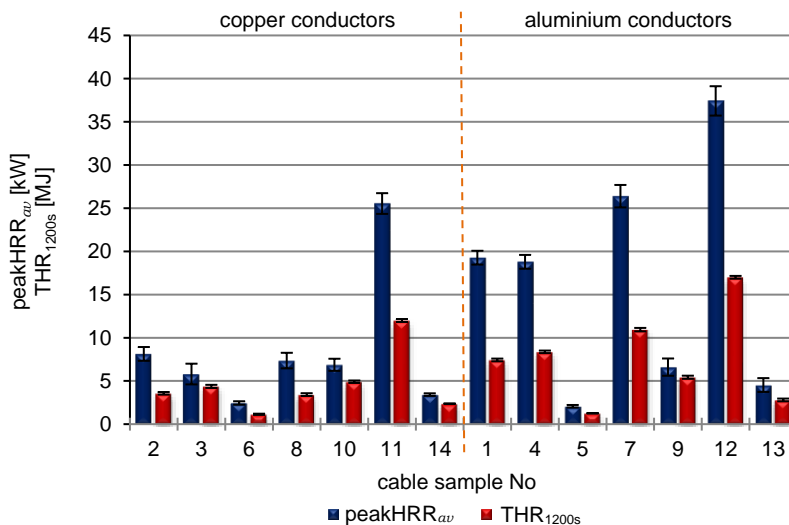

Fig. 28. Heat release results for cables with different conductor construction

The obtained heat release parameters and the FS (Tab. 4) of cables consisting of aluminium conductors was higher than for corresponding cable samples built with copper conductors.

The thermal conductivity of solid copper is equal to 401 W/(m×K), whereas for pure aluminium it is equal to 237 W/(m×K) [177]. Therefore, aluminium wires accumulate heat and its transfer is slower than for copper wires, causing increasing values of peakHRR_{av} and THR_{1200s} parameters for cable samples Nos. 1, 4, 5, 7, 9, 12 and 13. The value of the heat of combustion for aluminium (in the form of powder) is equal to 31 MJ/kg (7.43 kcal/g) [178, 179] and for copper it is equal to 2.4 MJ/kg (156 kJ/mole) [180] (almost 13 times lower than for aluminium). Moreover, aluminium contrary to copper can be involved in the combustion process to a certain degree. Smoke parameters (Fig. 29) do not differ significantly for cables of the same materials for sheaths, beddings and

insulation because the V_{combust} and the chemical nature of the materials used are similar in each case.

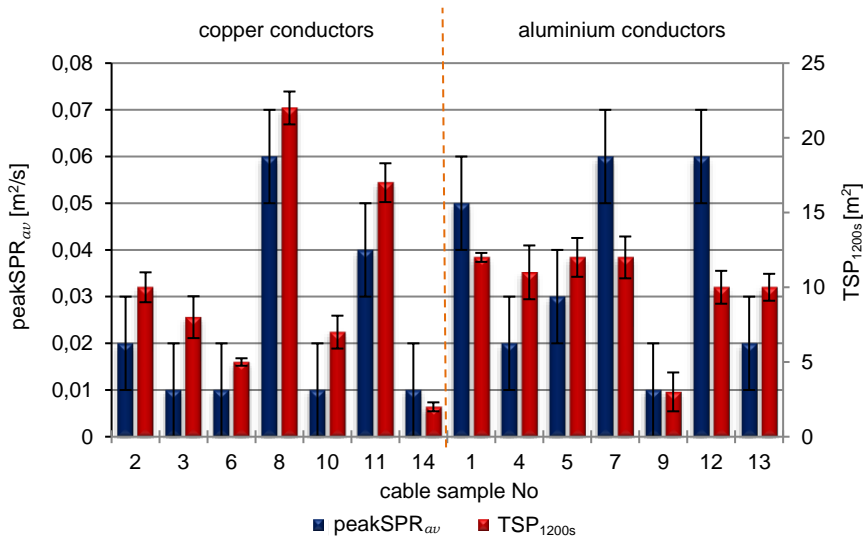

Fig. 29. Smoke production results for cables with different conductor construction

Test results for smoke generation (peakSPR_{av} and TSP_{1200s}) of cable samples with copper conductors show predominantly lower values than corresponding aluminium cables, mainly due to the lower non-metallic volume of the combustible material of those cables with few exceptions: cable samples Nos. 7 – 10. These cables were constructed of XLPE as insulation material, under galvanised steel wires as armour. The thermal conductivity of steel is relatively low among metals and equals to 58 (W/m×K). Heated steel wires give off heat, and thermal decomposition of the internal elements of the cable occurs. In consequence, dense smoke composed of aliphatic (saturated and unsaturated) and aromatic HCs and their derivatives is generated during the combustion process.

FS for all tested cable samples within group I was relatively low (below FS = 1.3 m) – Tab. 4. The close packaging of three or more conductors in each cable reduces flame penetration inside the inner layers and prevents the spreading of flame along the cables. Low cable parameters χ in the case of single-conductor cable No. 1 (χ equal to 1.6) and No. 2 (χ equal to 2.1) related to a volume of combustible materials within cables as well as the relatively high volume of non-combustible metallic content and diameter of conductors limit the spread of fire along those cables.

8.1.4. Conductor cross-section shape

Cable samples in group II (Tab. 2) were designed for the same low voltage rating (0.6/1 kV). Cable samples Nos. 16 and 25, 24 and 21, and 15 and 22 have the same number of conductors and cross-sectional area (Tab. 2), whereas cable samples Nos. 19 and 17, 27 and 23, 20 and 18, and 26 and 28 differ in the cross-sectional area of conductors between each other. Cable samples Nos. 19 and 17, and 20 and 18 have the same construction materials and similar cable parameter χ but differ in the cross-sectional area of the conductors. This contributed to the fact that only cable samples Nos. 15, 16, 17, 18, 19, 20, 21, 22, 24 and 25 were selected for in-depth analysis of the influence of conductor cross-section shape on the fire properties of cables.

The non-dependency of the fire properties of cables on sector-shaped and round cross-section shaped conductors has been demonstrated in the case of cable samples Nos. 16 and 25 (Figs 30 and 32), which are similar in construction except for the cross-section shape of the conductor. The test results for those two cables were similar and relatively low.

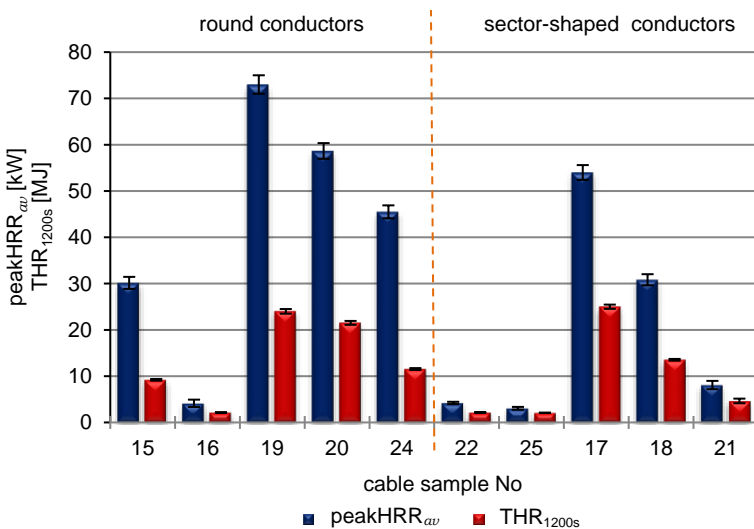

Fig. 30. Heat release results for cables with conductors of different shape

Cable parameters χ for cable No. 15 (equal to 4.0) and cable No. 16 (equal to 4.5) are relatively low, which causes similarities in the smoke results (Fig. 31).

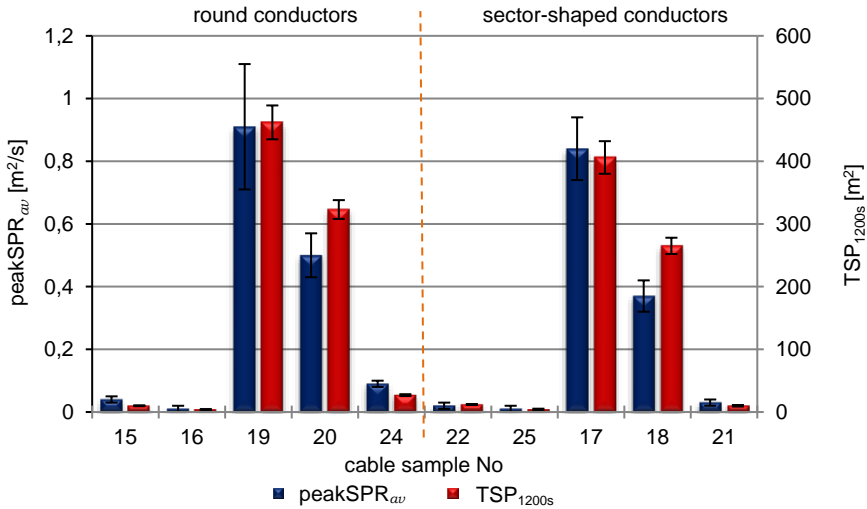

Fig. 31. Smoke production results for cables with conductors of different shape

For cable samples Nos. 24 and 21, 15 and 22, and 20 and 18, however, the difference in heat and smoke parameters (Figs 30 and 31) is significant. Higher values were obtained for cables No. 15, 19, 22 and 24 with round copper conductors than for cables with sector-shaped copper conductors. This was six and seven times higher in the case of peakHRR_{av}, two and four times higher in the case of THR_{1200s} and almost three times higher in the case of both smoke production parameters and FS (Tab. 4). This can be explained by the close packaging of metallic conductors and a difference in cable parameter χ , which is lower for cables containing sector-shaped conductors.

The same tendency is observed for cable samples Nos. 17, 18, 19 and 20, which are halogenated cables based on flame retarded PVC. The obtained results are relatively high, especially those related to smoke generation. Cable samples Nos. 17, 18, 19 and 20 are PVC-insulated and sheathed cables with an addition of flame retardants. Non-specific smoke results for PVC were obtained. The values of peakSPR_{av} (equal to 0.84 m²/s for cable sample No. 17 and 0.91 m²/s for cable sample No. 19) and TSP_{1200s} (equal to 406 m² for cable sample No. 17 and 462 m² for cable sample No. 19) were relatively low compared with the results of cable sample No. 64 (Tab. 4). The modification of PVC by using flame retardants, which act as smoke suppressants caused char formation, which has been widely discussed in the literature [181].

Cables consisting of sector-shaped conductors show obviously better fire properties than cables with round sectors because of the close agglomeration of conductors.

meration of metallic conductors within the cable cross-section, which are also shown as smaller cable diameters, whereas the χ parameters are similar (Tab. 2).

8.1.5. Number of conductors in cable construction

A not so clear relationship between fire properties and the V_{combust} made out of the same materials was observed (Figs 32 – 35). Therefore, in order to study the relationship between the number of conductors in cable construction and the fire properties of cables, two sets of cable families were selected from group III (Tab. 2).

The first set included cable samples Nos. 38, 40, 47 and 50, which consist of round copper conductors, non-halogenated insulations and outer sheaths. Cable samples Nos. 40, 47 and 50 consisted of non-halogenated beddings, which was not the case in the single conductor cable sample No. 38. In-depth analysis was performed on cable samples Nos. 33, 36, 42, 44, 45 and 48. All characteristics of the cable samples are given in section 5 (Tab. 2).

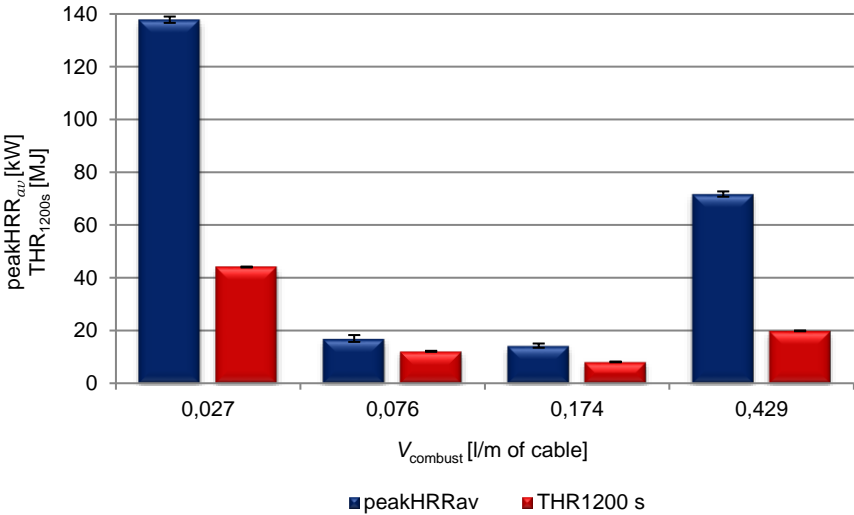

Fig. 32. *peakHRR_{av} and THR_{1200s} for tested cables vs their V_{combust} for cable samples No. 38, 40, 47 and 50*

Among large-scale tested samples, the highest heat release parameters (peakHRR_{av} equal to 138 kW and THR_{1200s} equal to 44 MJ) were obtained for the single conductor cable No. 38 – Fig. 32. This cable burned completely (FS = 3.5 m) – Table 4. The lowest parameters related to heat

release (peakHRR_{av} equal to 14 kW and THR_{1200s} equal to 8 MJ) were determined for cable sample No. 47, which consisted of 19 conductors. A not so clear tendency, however, was observed in the case of smoke generation during tests – Fig. 33.

The lowest value of the peakSPR_{av} and TSP_{1200s} parameters were obtained for a cable with 19 conductors (cable sample No. 47). This will be discussed in more detail on the basis of tests for six cable samples with better-known composition.

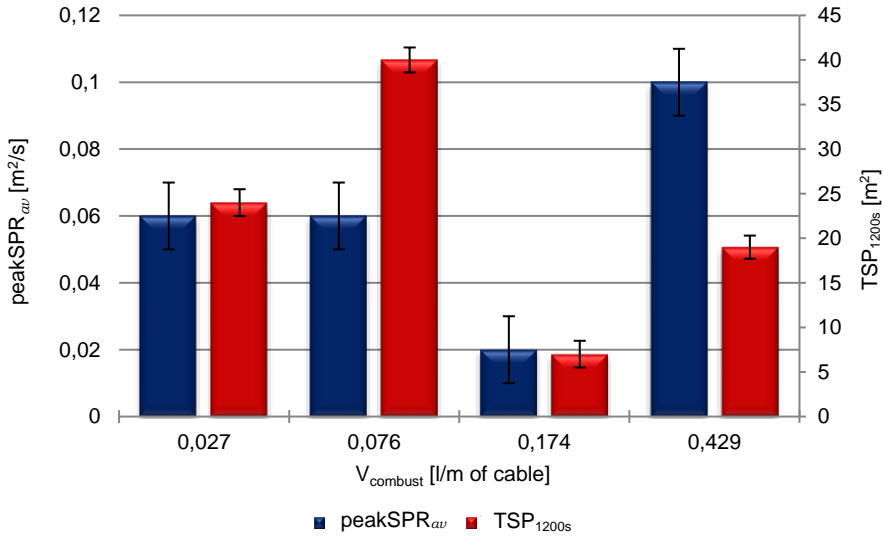

Fig. 33. peakSPR_{av} and TSP_{1200s} for tested cables vs their V_{combust} for cable samples No. 38, 40, 47 and 50

Cable samples Nos. 33, 36, 42, 44, 45 and 48 were taken for further analysis. The highest values of $\text{peakHRR}_{av} = 137.4$ kW and $\text{peakSPR}_{av} = 0.13$ m^2/s were obtained for the single conductor cable sample No. 33. The results for this cable were not presented in on the Figs 34 and 35 because they differed significantly from the others, and the intention of the author was to show the tendency in the obtained results. According to combustion theory and the definition of V_{combust} (non-metallic content), the measured value of HRR should increase with the value of V_{combust} . The experimental results (Figs 34 and 35), however, present different behaviour. The minimum peakHRR_{av} and THR_{1200s} values were found for the 19-conductor cable sample No. 44 (equal to 7 kW) and the peakHRR_{av} and THR_{1200s} values increased with V_{combust} for cables having more than 19 conductors.

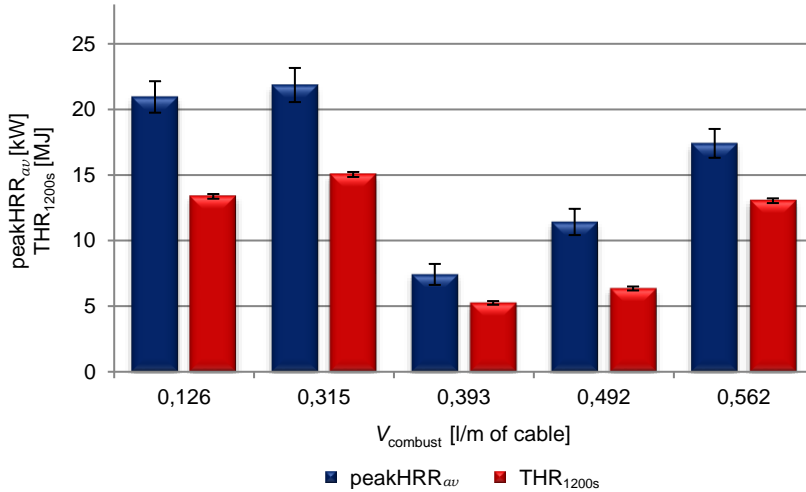

Fig. 34. $peakHRR_{av}$ and THR_{1200s} for tested cables vs their V_{combust} for cable samples Nos. 36, 42, 44, 45 and 48

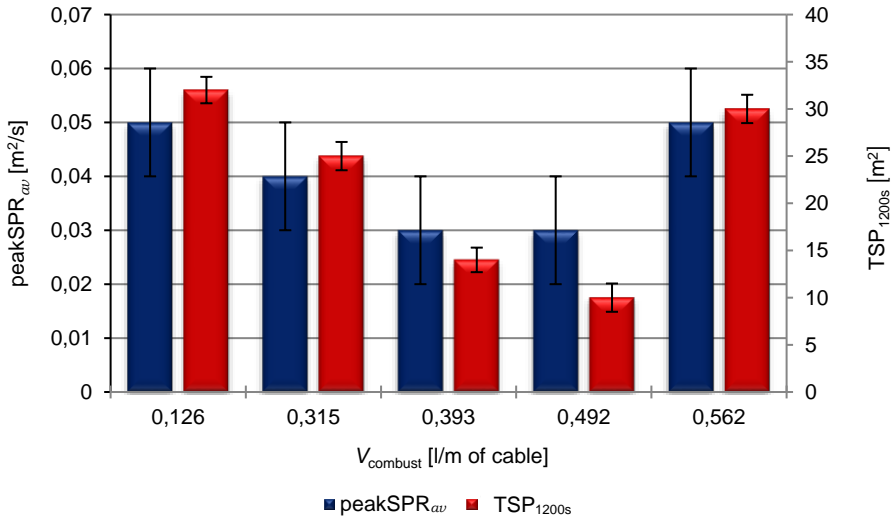

Fig. 35. TSP_{1200s} and $peakSPR_{av}$ for tested cables vs their V_{combust} for cable samples Nos. 36, 42, 44, 45 and 48

A similar dependency was found in the case of the effective heat of combustion (EHC) and FS, and the average speed of flame spread (v_{av}) for cables with different number of conductors (Tab. 5).

Table 5. Fire parameters for tested cables vs their V_{combust}

Cable sample No.	No. of conductors	V_{combust} [l/m of cable]	THR [MJ]	TSP [m ²]	FS [m]	Δm^* [-]	EHC [MJ]	ν_{av} [m/min]
1	2	3	4	5	6	7	8	9
33	1	0.032	44	53	3.3	0.39	113.7	0.17
36	3	0.126	13	32	1.12	0.45	29.7	0.06
42	14	0.315	15	25	1.18	0.49	30.7	0.06
44	19	0.393	5	18	0.79	0.50	10.5	0.04
45	24	0.492	6	10	0.92	0.53	12.0	0.05
48	30	0.562	13	30	0.95	0.45	29.0	0.05

* Absolute mass loss determined using TGA analysis.

The relationship between peakHRR_{av} and peakSPR_{av} for the tested (low-smoke zero-halogen) cables varies according to the number of copper conductors and the V_{combust} of cables. The THR_{1200s} as a function of V_{combust} for the same cables (Fig. 34, Tab. 5) is similar in both cases.

The lowest values of total smoke production TSP_{1200s} and maximum average smoke production rate peakSPR_{av} (Fig. 35) were received for 19- and 24-conductor cable samples Nos. 44 and 45. PeakSPR_{av} values, however, are relatively low in the case of each tested cable, which contains more than one conductor.

The ν_{av} has been calculated as a FS obtained during 20 min of test duration since the burner was applied. The highest ν_{av} (equal to 0.17 m/min) was obtained for a single conductor cable, which does not consist of bedding (inner covering). This has an effect on cable fire properties, as the tight packaging inside the cable does not allow flame penetration into its inner layers.

The TGA and ATR-FTIR analysis indicate that there were no significant differences among the chemical formulations between outer sheaths and beddings for cables subjected to testing in both small and large geometrical scale. Small differences in insulation composition were found. This could be explained by the inhomogeneous distribution of inorganic fillers or the different content of fillers within the polymer fraction. The large amount of incombustible fillers used in the cable samples (mainly ATH) strongly influences their fire properties, reducing their flammability.

The thermal decomposition of the combustible elements of cable samples Nos. 33, 36, 42, 44, 45 and 48 is shown as oxidative mass losses together with increasing temperature – Figs 36 a) and b) and 37.

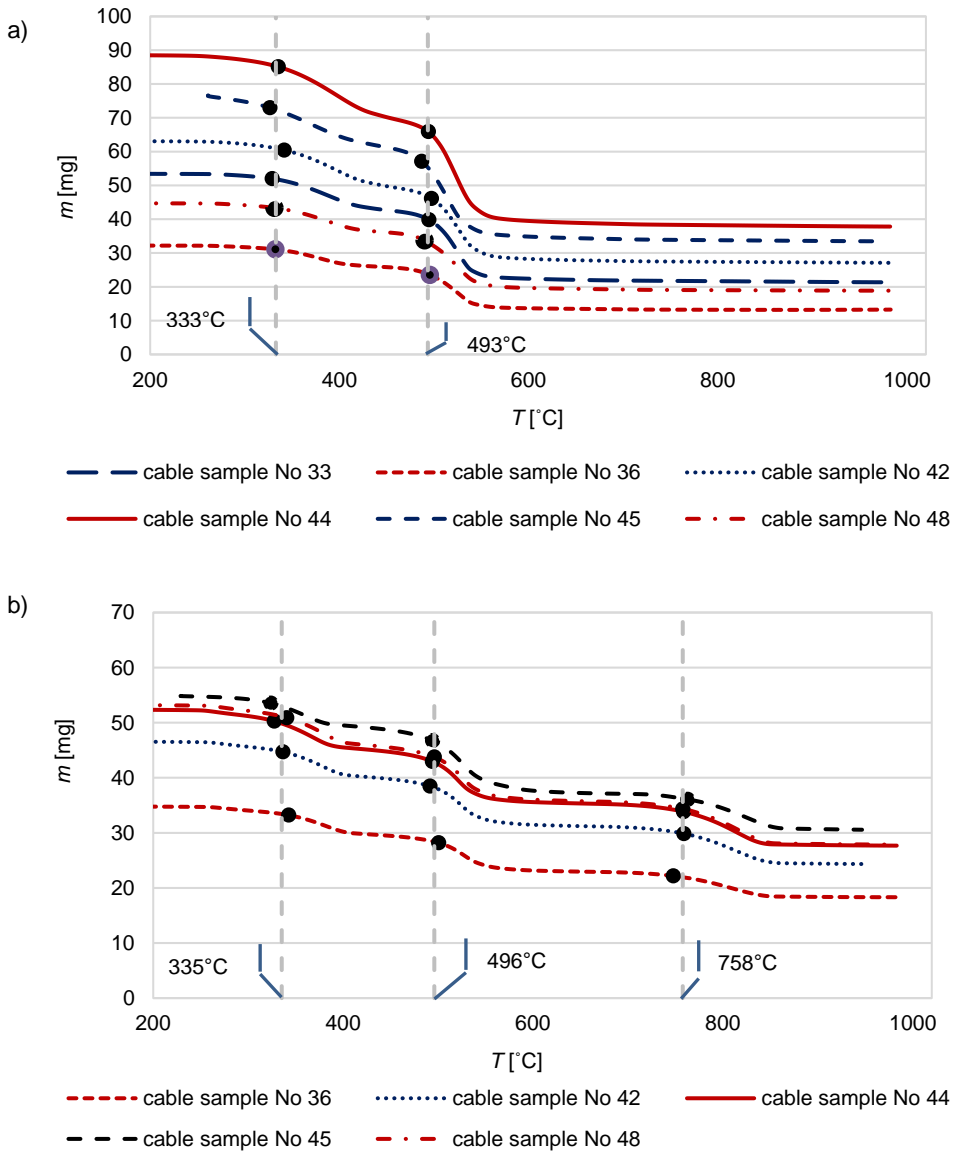

Fig. 36. TGA curves of cable materials a) outer sheaths, b) beddings

The profiles of TGA curves for the outer sheaths and beddings of the tested cables – Figs 36 a) and b) are similar in each case. The vertical lines show two characteristic onset temperatures indicating the extrapolated temperatures of the beginning of the processes, where the preliminary and subsequent steps of thermal decomposition of the material

took place. They represent similar trends of decomposition temperatures for each sheathing material. The mass loss of those compounds oscillated between 56% for 24-conductor cable (cable sample No. 45) and 60% for single conductor cable (cable sample No. 33). About 40% of sheaths have incombustible inorganic fillers. This observation showed that there is no significant difference in chemical composition between the outer sheaths of cables. In the case of beddings (Fig. 36b), three characteristic temperatures of decomposition reactions were observed: about 335°C (+/-0.66°C), 496°C (+/-0.66°C) and 758°C (+/-0.66°C), which are shown as vertical trend lines. The mass loss of bedding compounds of the tested cables was similar in each case (about 44 – 48%).

The largest differences between mass losses in the TGA analysis of insulations were observed between 1-, 3- and 30-conductor cables (cable samples Nos. 33, 36 and 48; about 60%) and 14-, 19-conductor cables (cable samples No. 42 and 44; about 47%) – Fig. 37.

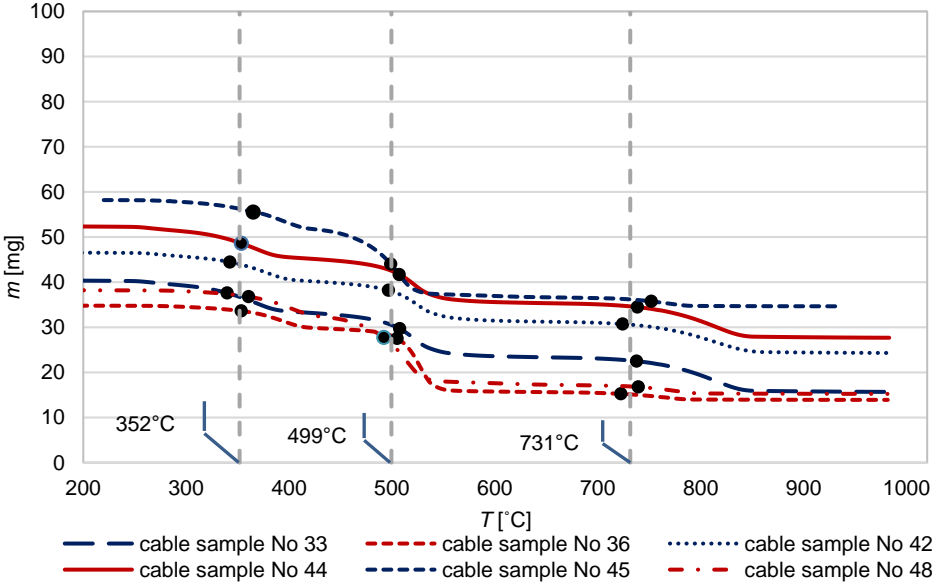

Fig. 37. TGA curves of conductor insulations of tested cables

The lowest mass loss, equal to 40%, was observed for 24-conductor cables (cable sample No. 45). The reason is probably the inaccurate distribution of inorganic fillers or the different content of fillers within the polymer fraction. The results in temperature levels when decomposition

starts, however, are similar in each case, and are as follows: 352°C (+/-0.66°C), 499°C (+/-0.66°C) and 731°C (+/-0.66°C).

The characteristic temperatures of the decomposition (onset temperatures) of materials used for the formulation of outer sheaths, beddings and conductor insulations became similar for each tested cable.

The ATR-FTIR spectra for each tested construction material of cables ("fingerprint" method) were used for material similarity confirmation (Figs 38, 39 and 40). Characteristic absorbance (Abs) peaks appeared at specific wave numbers characterising the single chemical bonds in the materials used for cable formulation.

A very good correlation between each outer sheath spectrum was demonstrated (Fig. 38). The wave numbers and absorbance peaks were similar. The correlation factor for outer sheaths (more than 0.91) pointed to the similarity of materials used for sheath formulation.

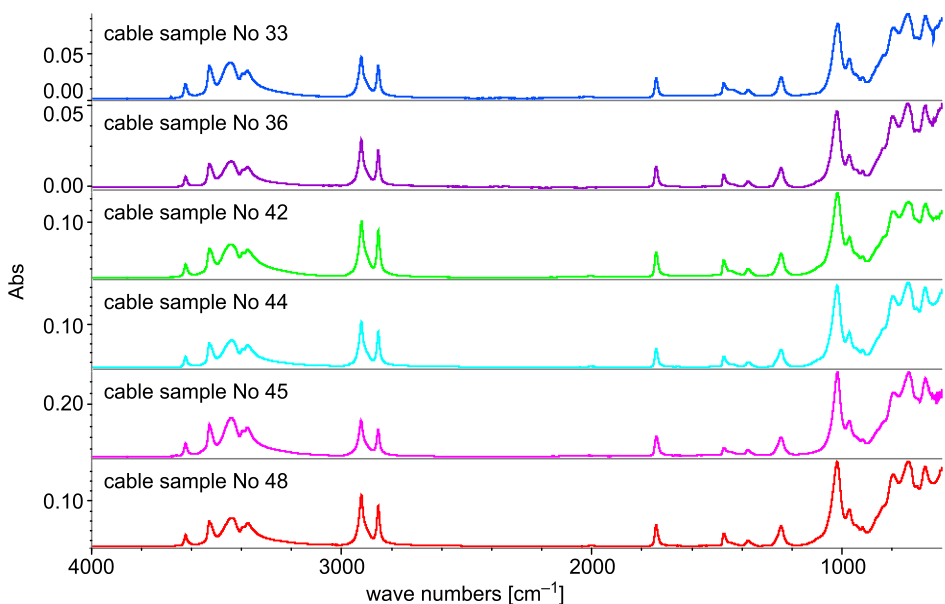

Fig. 38. FTIR spectra of outer sheaths of tested cables

The wave numbers of characteristic peaks from bedding samples (Fig. 39) are similar for each tested cable. The intensity (absorbance) of peaks, however, points to differences in the amount of chemical species content within the polymer fraction.

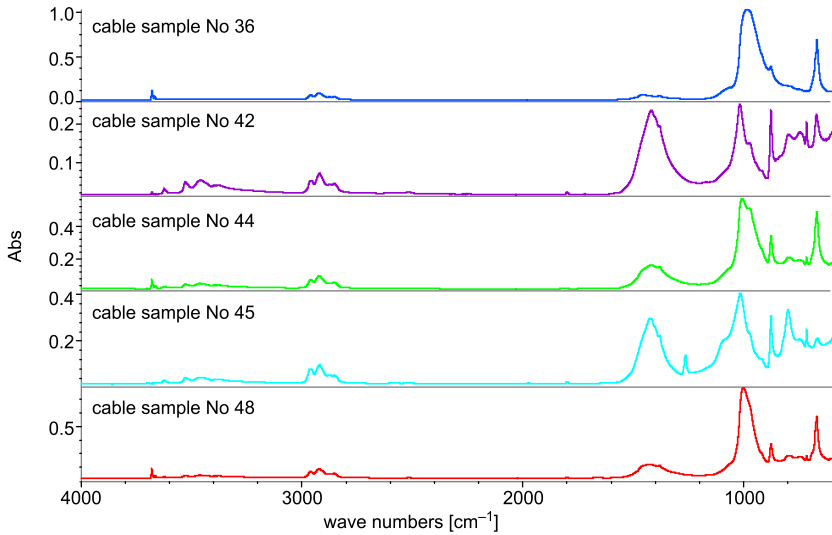

Fig. 39. FTIR spectra of beddings of tested cables

Similar distribution of peaks and changes in the intensity of characteristic peaks on the spectra have been observed in the case of cable insulations (Fig. 40). This observation can also be explained by differences in the amount of chemical species in both bedding and conductor insulation materials.

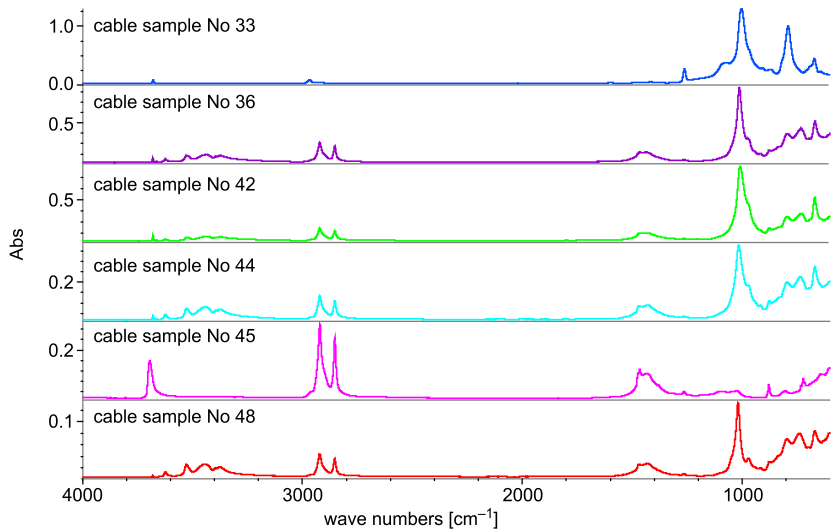

Fig. 40. FTIR spectra of conductor insulations of tested cables

These comparisons simply show the similarity of materials used for cable formulation. The differences between decomposition temperatures and mass losses at TGA analysis and the changes in intensity (absorbance) of FTIR peaks show a difference in inorganic fillers (even up to 60% for cable samples No. 33, 36 and 48 cable insulations). The large amount of incombustible fillers (mainly ATH) also influences the fire properties of cables, reducing their flammability.

It could, therefore, be argued that, to some extent, the construction of cables, especially the number of conductors, as well as the amount of incombustible fillers influence the final fire behaviour of cables because they form a barrier against the external flames penetrating the cable before ignition.

Summarising, for single conductor cables, which consist only of an outer sheath and conductor insulation, the highest values of heat, smoke parameters and parameters related to FS in cables were obtained, whereas the lowest values of peakHRR_{av}, and THR_{1200s}, EHC and FS were determined for cables with 19 conductors (cable sample No. 44). Similar results were observed for TSP_{1200s}. This phenomenon can be explained by the compact structure caused by the close packaging of copper conductors (conductors) in the case of multi-conductor cables, which creates a barrier against flame penetration inside the closed agglomeration of metallic wires. This hinders the access of oxygen to the combustion zone and the emission of volatile combustion products. The presence of the filling compound (bedding) results in much lower values of the parameters characterising the combustion process (peakHRR_{av}, THR_{1200s}, peakSPR_{av} and TSP_{1200s}) than for single conductor cables, where the flame penetrates the sample cross-section without additional barriers.

Similar trend was observed for cables with more than 19 conductors (cable sample No. 44), where the heat release parameters increased together with the V_{combust} of the cables. This phenomenon is additionally accelerated by the intumescent structure formulation from ATH fillers, which in the case of fire are shown as residue in the TGA analysis of each cable construction material. The obvious conclusion is that more ATH fillers in non-metallic combustible materials lead to better fire properties. The role of the ZnB filler as a flame retardant must also be underlined.

8.1.6. Materials used for non-metallic element formulation

Copper and aluminium pairs of cables identical in construction, with the exception of the material used for the outer sheath, bedding and insulation (Tab. 2), have been used as samples in this study. Cable samples Nos. 65, 69, 70 and 71 differed only in the material used for insulation;

the rest of the construction materials were the same. Cable samples Nos. 63, 65, 71 and 72 were non-halogenated cables, whereas the corresponding cable samples Nos. 62, 70, 69 and 73 consisted of one or two halogenated non-metallic elements based on a PVC compound. The outer sheath of cable sample No. 62, however, included flame-retardants/smoke suppressants in its formulation. Cable sample No. 65 was used as a fire-resistant cable with additional incombustible mica tape placed over the copper conductors.

The maximum values of peakHRR_{av} and THR_{1200s} were obtained for cable samples Nos. 69, 70 and 73 (Fig. 41), whereas for cable samples Nos. 71, 65 and 72 the results were relatively low.

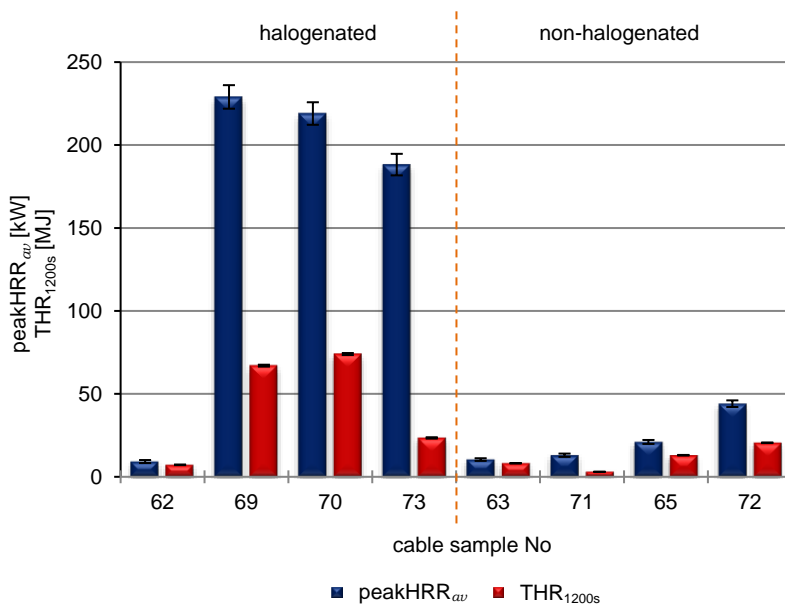

Fig. 41. Heat release results for cables of different non-metallic construction materials

The highest level for each parameter was obtained for cable sample No. 70 ($\text{peakHRR}_{av} = 229$ kW, $\text{THR}_{1200s} = 67$ MJ, $\text{TSP}_{1200s} = 155$ m² and $\text{peakSPR}_{av} = 0.48$ m²/s) consisting only of PVC-based non-flame retarded outer sheath and insulations, and non-vulcanised EPDM as bedding. These cables burned completely, which is shown as $\text{FS} = 3.5$ m (Tab. 4). Only conductors, inorganic fillers and char were left behind on the test ladder. Cable sample No. 62 consisted of flame retardants, which reduce the heat release parameters, consequently causing noticeable differences in heat results in comparison with non-halogenated cable sample No. 63.

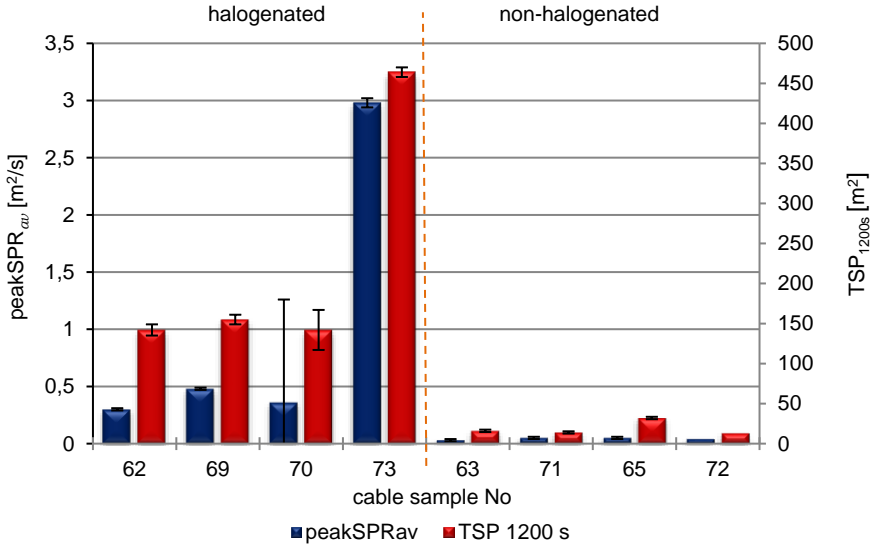

Fig. 42. Smoke release results for cables of different non-metallic construction materials

Increasing TSP_{1200s} and peakSPR_{av} values obtained (Fig. 42) for cable samples Nos. 69, 70 and 73 can be explained as follows: in PVC-containing cables, a large amount of volatile saturated, unsaturated and aromatic HCs, as well as char, was formed during combustion processes – mostly through cyclisation and chain scission radical reactions (Fig. 43) [182, 183].

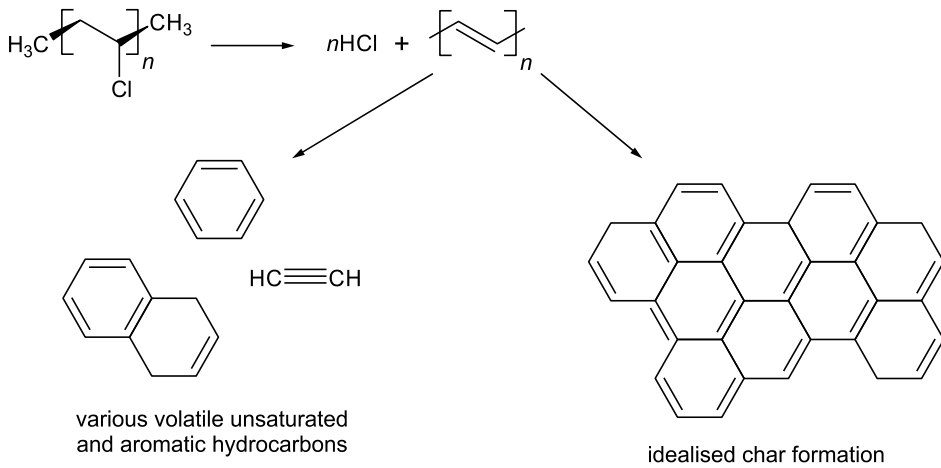

Fig. 43. Thermal decomposition of PVC [109]

The HRR is proportional to oxygen consumption during the combustion process for most combustible materials and is assessed indirectly by using the concentrations of products of complete combustion [184]. Thus, the high concentrations of CO₂, CO and HCs generated during the combustion process, preceded by oxidising reactions of PVC materials, may be the result of the typical radicals' reaction for PVC-containing cables [185]. This results in high values of heat and smoke parameters obtained for halogenated cables.

The heat and smoke parameters of cable samples Nos. 69, 70 and 73 were much higher than for cable samples of similar construction (Nos. 71, 65 and 72). Low values of fire parameters were obtained, among others, for cable sample No. 65 (peakHRR_{av} = 21 kW, THR_{1200s} = 13 MJ, TSP_{1200s} = 32 m² and peakSPR_{av} = 0.05 m²/s), for which the stable intumescent structure is formed from ATH/ZnB fillers (4) reducing flammability within the cable's outer sheath during a self-sustained combustion process. The ancillary flame-retardant effect of ZnB and ATH consists of an endothermic releasing of water during the thermal decomposition process and the formation of a glassy layer on the material's surface [138, 148]. Water as a product of chemical reaction (3) eliminates air from the combustion zone and dilutes the flammable gases.

PVC-containing cables produce a large amount of smoke, including toxic products such as CO₂, CO, various HC and HCl, especially under ventilation-controlled fires.

In the presence of PVC materials in cable formulation, it is necessary to show the impact of fire effluent toxicity. In order to examine the dependence of the amount of combustion gases on ventilation-controlled conditions, an H07V-U PVC-based copper electric wire (Fig. 44) was chosen for experiments because of the simplicity of its construction.



Fig. 44. H07V-U PVC-insulated electric wire

It is also widely used in electrical installations in buildings throughout Europe. There was, however, lack of information on the content of plasticiser and fire retardants present in the cable. It is known that PVC is filled with calcium carbonate and ATH, which may influence the fire properties of the tested wire.

PVC-based copper electric wires (external diameter of approximately 3.0 mm, diameter of conductor 1.36 mm, and weight of cable 21 kg/km) were investigated at a temperature of 650°C and in set airflows equal to 2, 5, 10 and 15 l/min. The total airflow, which is a sum of primary and secondary airflows, did not exceed 50 l/min. The length of cable specimens were 600 mm. Details of the tests are summarised in Tab. 6. According to the literature data [113], the temperature of 650°C is the highest empirically estimated at which a fire occurs under well-ventilated conditions. The methods of testing cables on a semi-real scale and testing in a cone calorimeter are well-ventilated tests (with continuous air flow, i.e. free access of fresh oxidant to the combustion zone), which was a direct factor determining the selection of combustion conditions for electrical cable samples in well-ventilated conditions.

Table 6. Test conditions and specimens' description

Specimen No.	Specimen description	ϕ [-]	Primary airflow [l/min]
1	PVC wire	0.82	2
2	PVC wire	0.42	5
3	PVC wire	0.37	10
4	PVC wire	0.27	15
5	Pure PVC polymer	0.04	10
6	Pure LDPE polymer	0.10	10

The yields of combustion gases were calculated according to the ISO 19700 [109] specification. Due to the construction of cables and wires, complete combustion is not possible because of the metallic (copper in the current study) conductor and the large amount of inorganic fillers, which are incombustible. The yield of each fire gas may be presented as a function of the mass of the entire cable or of the mass loss of a non-metallic fraction. The results were presented as a function of mass loss of a non-metallic fraction.

For the PVC wire only, the loss of mass of the polymer (PVC) fraction was included in the yield calculations. The ventilation conditions were

indicated by equivalence ratios ϕ , calculated using the oxygen concentration inside the tube furnace in each test according to equation (4) [31] (Figs 45, 46, 47 and 49)

$$O_{2(\text{tube})} = \frac{\text{total airflow}}{\text{primary airflow}} \left(O_{2(\text{mixing chamber})} - \frac{20.95 \times \text{secondary airflow}}{\text{total airflow}} \right) \quad (4)$$

where the total airflow = 50 l/min in the test equipment.

The equivalence ratio ϕ for cable was determined adequately for commercial products and other materials of unknown composition, assuming that the required stoichiometric amount of air is known. The amount of oxygen (oxidant) in the gas phase was estimated with the use of a paramagnetic analyser, which allowed the determination of the O_2 concentration left after complete oxidation of combustion products in the secondary vertical furnace (full combustion at 900°C).

As a reference for the results of the experiments, pure unplasticised PVC and the simplest reference polymer – LDPE – were tested at 10 l/min airflow through the tube (Figs 45, 46, 47). LDPE was chosen as an example of polymer, which does not contain chlorine in the polymer chain. A thorough discussion of the results is difficult because producers do not provide details about the components of PVC polymeric materials used for cable formulation.

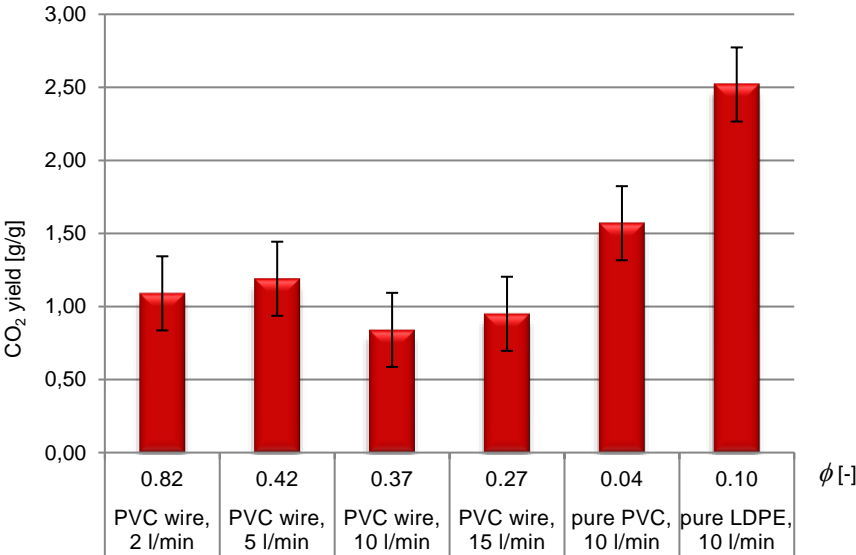

Fig. 45. CO₂ yield (mass loss basis) for H07V-U cable, pure PVC and pure LDPE polymers at different ventilation conditions

CO₂ yields for the H07V-U PVC-based electric copper wire was tested at set primary airflows, and pure unplasticised PVC and pure LDPE at 10 l/min of primary airflow (Fig. 45). For the tested wire, lower values of CO₂ yield at different ventilation conditions were obtained, whereas for both pure polymers the yields were higher at well-ventilated conditions: three times higher in the case of pure LDPE and two times higher for pure PVC. It was previously shown [26, 114, 123, 186] that pure unplasticised PVC burns with a low HRR, because the halogen atoms in the structure release HCl (almost 60%_w), which then inhibits the conversion of CO to CO₂. This process is more complex in the case of plasticised PVC filled with various fillers, especially flame-retardants.

For a ϕ of 0.82, lower CO yield (0.32 g/g) – Fig. 46 was observed than expected. This was due to the experimental conditions, where the set primary airflow at 2 l/min is relatively low. This forced the set secondary airflow (48 l/min) to transfer back into the tube to the combustion zone and resulted in more effective oxidation.

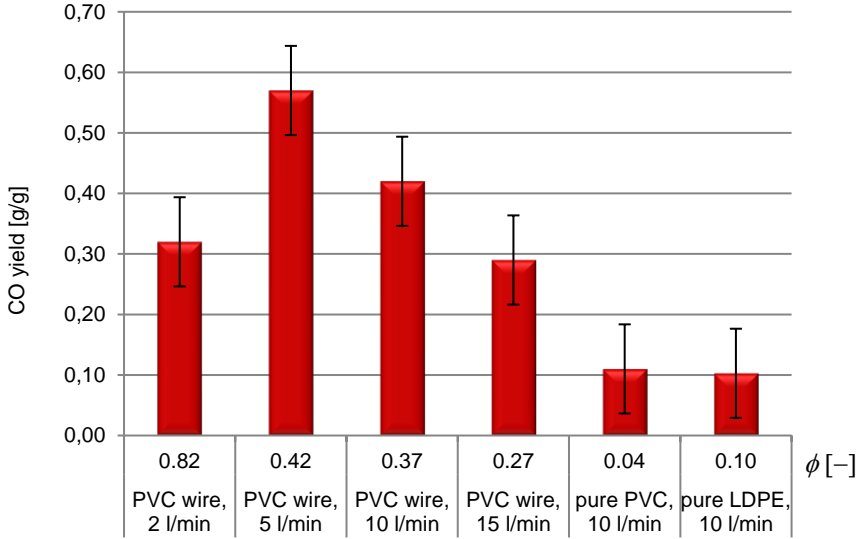

Fig. 46. CO yield (mass loss basis) for H07V-U cable, pure PVC and pure LDPE polymers at different ventilation conditions

The reference value for the pure PVC polymer was equal to 0.11 g/g of CO, which was approximately four times higher than the corresponding values of the PVC-based copper electric wire (0.42 g/g) tested at the same ventilated conditions (10 l/min).

The dependence of HC (product of incomplete combustion) yields was a function of increasing ventilation conditions and equivalence ratio ϕ (Fig. 47).

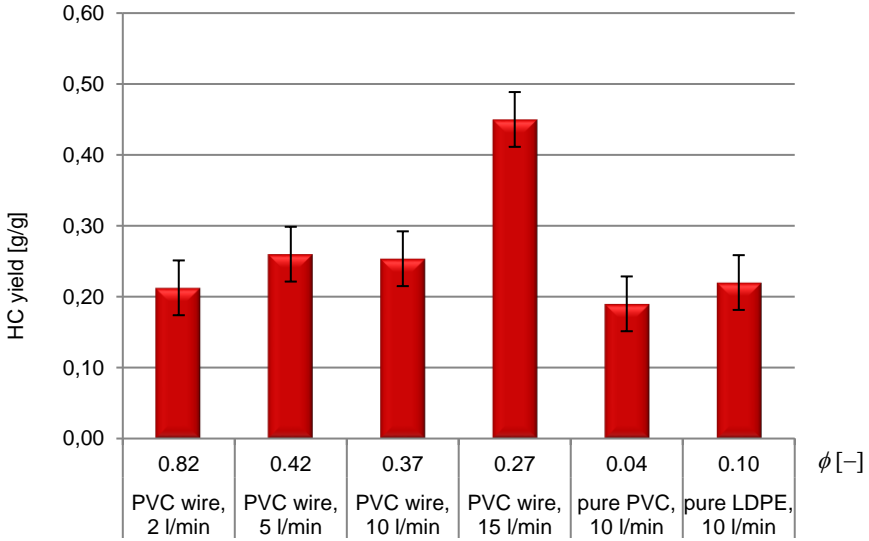

Fig. 47. HC yields (mass loss basis) for H07V-U cable, pure PVC and pure LDPE polymers at different ventilation conditions

There was no clear tendency observed. In essence, the measured yields resembled the reference values except for $\phi = 0.27$, where the obtained HC yield was equal to 0.45 g/g. It was previously discussed [187] that PVC yields a consistently high level of products of incomplete combustion arising both from flame inhibition by HCl and oxygen depletion, even at well-ventilated fire conditions).

During the combustion process, most cables self-extinguished and then reignited. As a consequence, the non-flaming period may result in high concentrations of products of incomplete combustion, such as CO and various HCs. This is shown as fluctuations on the graph in Fig. 48.

A significant increase in HC yield at 15 l/min primary airflow could also be a consequence of aromatic HCs emission obtained by cross-linking, and the intramolecular decomposition of polyene segments resulting from dehydrochlorination [188]. Even at $\phi < 1$, various light HCs produced during the decomposition of PVC are observed, which may be due to a larger proportion of smaller volatile species than large ones remaining as soot.

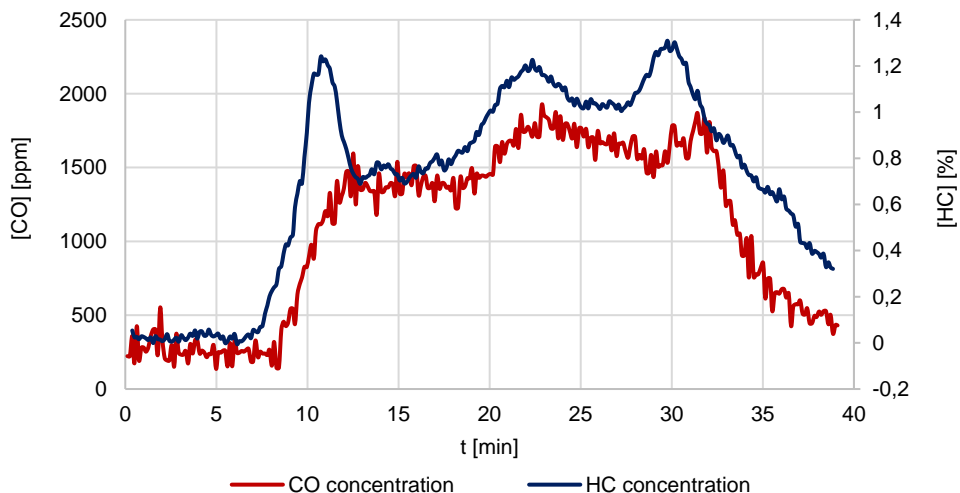

Fig. 48. CO and HC concentration changes during the steady state combustion test of H07V-U wire at 15 l/min primary airflow

The difference between HCl yields from PVC-based copper wire and pure unplasticised PVC is significant. The HCl yields (Fig. 49) in fire effluents obtained from the PVC-based copper wire were similar in all ventilation conditions and, as expected, show about 1.5 times lower values (about 0.3 g/g in each case) than pure PVC polymer (yield equal to 0.45 g/g).

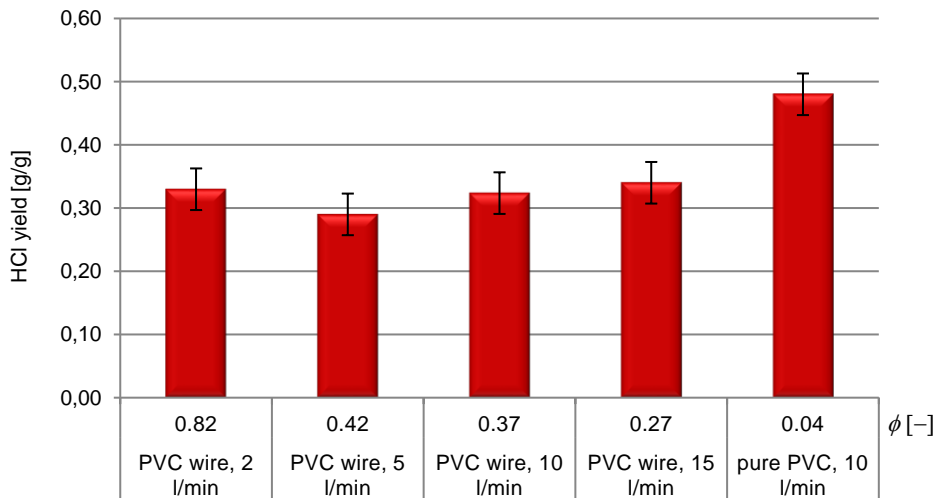

Fig. 49. HCl yield (mass loss basis) for H07V-U cable and pure PVC polymer at different ventilation conditions

Plasticised PVC, used as cable insulation material, is often filled with calcium carbonate (chalk) and a flame retardant, such as antimony trioxide (Sb₂O₃) or aluminium trioxide (Al₂O₃). This may yield only one third of the HCl, but high levels of CO (Fig. 46) [26].

Antimony trioxide reacts with HCl released from burning PVC to form antimony oxychloride, which then decomposes to form antimony trichloride (SbCl₃). The aluminium trioxide flame-retardant mechanism is based on the release of water, which cools the combustion zone and dilutes active species. An intumescent structure is also formed [189].

The high values of CO₂, CO and HC yields may be the result of the typical radicals' reaction for PVC. HCl production is dependent on temperature and occurs during the stripping reaction (Fig. 43).

Two equations have been developed for the estimation of the FED from the chemical composition of the environment in the physical fire model. Each begins with the precept that the fractional lethal doses of most gases have an additive effect [26, 175].

The first is the N-Gas Model developed by NIST. The FED for the N-Gas model (equation 5) assumes that only the effect of the main toxicant CO is enhanced by the increase in respiration rate caused by high CO₂ concentrations (expressed as a step function with one value of *m* and *b* for CO₂ concentrations below 5% and another for those above 5%) [190, 191, 192].

$$FED = \frac{m[CO]}{[CO_2] - b} + \frac{21 - [O_2]}{21 - LC_{50,O_2}} + \frac{[HCN]}{LC_{50,HCN}} + \frac{[HCl]}{LC_{50,HCl}} + \frac{[HBr]}{LC_{50,HBr}} + \dots \quad (5)$$

where:

- a* and *b* – respectively the slope and intercept of the interactive curve of CO and CO₂ which depicts the increasing toxicity of CO and CO₂ concentration increases [-],
- [O₂] – concentration of O₂ [%v],
- [HCN] – concentration of HCN [ppm],
- [HCl] – concentration of HCl [ppm],
- [HBr] – concentration of HBr [ppm],
- [CO₂] – concentration of CO₂ [%v],
- [CO] – concentration of CO [ppm],
- LC_{50,O₂} – LC₅₀ of O₂ [%v],
- LC_{50,HCN} – LC₅₀ of HCN [ppm],
- LC_{50,HCl} – LC₅₀ of HCl [ppm],
- LC_{50,HBr} – LC₅₀ of HBr [ppm].

The values of a and b depend on the concentration of CO_2 . If $[\text{CO}_2] \leq 5\%$, $a = -18$ and $b = 122000$, and if $[\text{CO}_2] > 5\%$, $a = 23$ and $b = -38600$.

In the Purser model (equation 6), the CO_2 concentrations are considered as a multiplication factor related to hyperventilation. The increasing effect of all toxic and irritant species was shown, which varies continuously over the range of CO_2 concentrations.

$$\text{FED} = \left(\frac{[\text{CO}]}{\text{LC}_{50,\text{CO}}} + \frac{[\text{HCN}]}{\text{LC}_{50,\text{HCN}}} + \frac{[\text{HCl}]}{\text{LC}_{50,\text{HCl}}} + \frac{[\text{HBr}]}{\text{LC}_{50,\text{HBr}}} + \dots \right) V_{\text{CO}_2} + A + \frac{21 - [\text{O}_2]}{21 - \text{LC}_{50,\text{O}_2}} \quad (6)$$

where:

- $[\text{O}_2]$ – concentration of O_2 [%v],
- $[\text{HCN}]$ – concentration of HCN [ppm],
- $[\text{HCl}]$ – concentration of HCl [ppm],
- $[\text{HBr}]$ – concentration of HBr [ppm],
- $[\text{CO}]$ – concentration of CO [ppm],
- $\text{LC}_{50,\text{O}_2}$ – LC_{50} of O_2 [%v],
- $\text{LC}_{50,\text{CO}}$ – LC_{50} of CO [ppm],
- $\text{LC}_{50,\text{HCN}}$ – LC_{50} of HCN [ppm],
- $\text{LC}_{50,\text{HCl}}$ – LC_{50} of HCl [ppm],
- $\text{LC}_{50,\text{HBr}}$ – LC_{50} of HBr [ppm].

$$V_{\text{CO}_2} = 1 + \frac{\exp(0.14[\text{CO}_2]) - 1}{2} \quad (\text{multiplication factor for } \text{CO}_2 \text{ driven hyperventilation}),$$

A – acidosis factor, where $A = 0.05 [\text{CO}_2]$.

FED data (presented in Figs 50 and 51) show the importance of fire gases such as CO, HCs and HCl from a toxicological point of view. It is shown that hypoxia, which is due to oxygen depletion in the fire zone, is almost negligible and not relevant for fire effluent toxicity from PVC cables.

The difference between the contribution of FED in the Purser Model and N-Gas Model is due to multiplication by hyperventilation and acidosis factors, although the trend has been maintained in both cases. The highest FED contributions have been obtained for 10 l/min airflow, where the highest FED of CO was achieved. Both FED_{CO} and FED_{HCl} depend on the lethal concentration LC_{50} , which is high for both gases (Tab. 3). The summarised FEDs increase up to 10 l/min of set airflow and then slightly decrease to 1.40 (N-Gas Model) and 1.49 (Purser Model).

HCl formation is the critical stage of the PVC decomposition phase [183] (Fig. 43) and is due, among others, to the oxidation and decomposition processes. Therefore, the amount of available oxygen is crucial in this process and depends on ventilation efficiency. Even an exiguous

amount of highly reactive radicals can cause propagation of the oxidation process in the gas phase. Low hypoxia is also the result of this process.

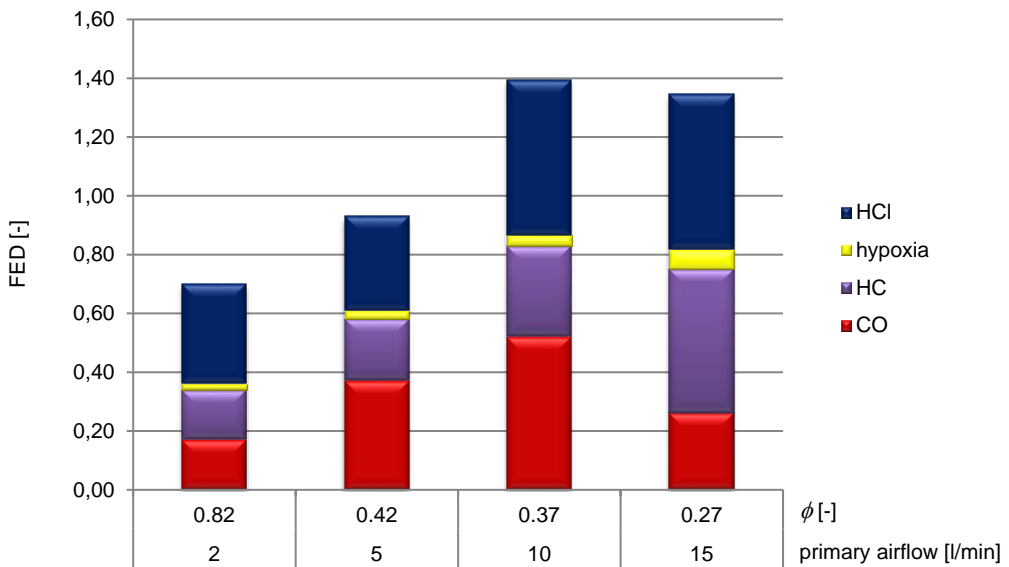

Fig. 50. N-Gas Model FED contribution for H07V-U wire at different fire conditions

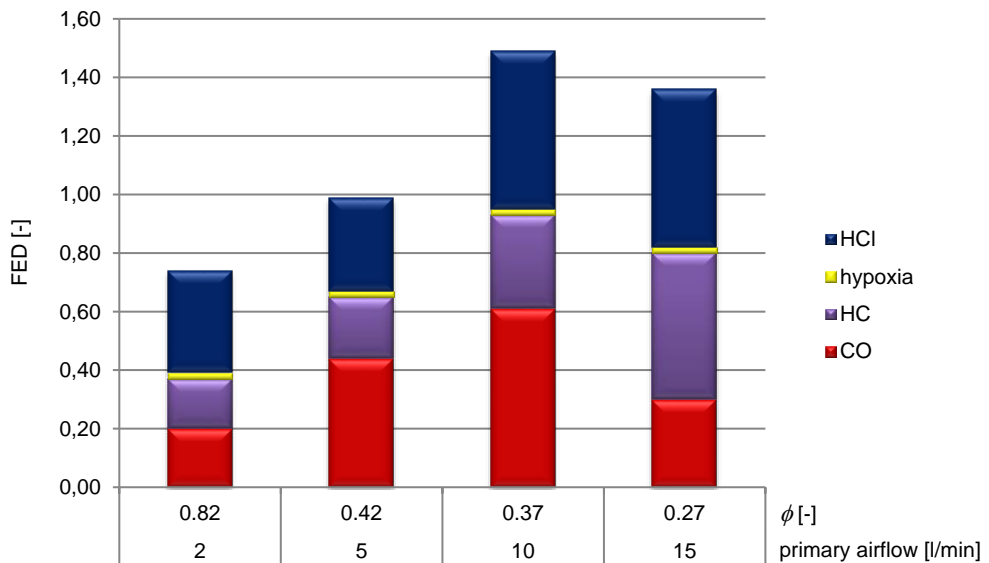

Fig. 51. Purser Model FED contribution for H07V-U wire at different fire conditions

The relatively weak bond of chlorine atoms to carbon atoms within the PVC chain causes the early generation of HCl leading to the gasification of an equivalent mass of carbon [104]. The weakest bond in PVC is C-Cl, at the tertiary carbon atom, and it is from this bond that the degradation begins. These types of bonds are formed at the stage of synthesis as a result of uncontrolled kinetic transfer to the polymer chain, resulted in branching.

Since HCl can be released before significant carbon from the material is combusted, the mass yield of HCl can exceed the stoichiometric value early in the material's decomposition. Far better results have been found for PVC insulation rather than for pure unplasticised PVC, because insulation material contains a high fraction of calcium carbonate filler (chalk), as previously mentioned by Gann et al. [193].

Consequently, when the number of these highly reactive radicals constantly increases, ignition and flaming combustion occur. This process can be described by reactions (7) and (8).



In the reactions given above and below (7) – (13), each dot “·” represents an unpaired electron.

For example [109, 110, 114], in the presence of halogen-containing compounds, the above radical chain mechanism in the gas phase is changed due to the creation of chlorine radicals and HCl – equations (9) – (13). The high energy OH· and H· radicals formed by chain branching is removed by halogen-containing compounds (RCl) – polymers.



The removal of H· is key to eliminate the main chain branching step.



The removal of OH· blocks the main heat release step of HC combustion, namely the conversion of CO to CO₂, through replacement with less reactive halogen radicals in the gas phase [194]. The H· and OH· radicals are essential for many flame reactions and are involved in the main heat release in reaction 13



Loss of $H\cdot$ and $OH\cdot$ reduces the CO_2 / CO ratio. The high energy $H\cdot$ and $OH\cdot$ radicals are removed through a reaction with HCl and replaced with low energy $Cl\cdot$ radicals. The actual flame-retardant effect is thus produced by HCl . Chlorine consumption is regenerated through reaction with HCs (10). As a consequence, higher HCl yields are obtained for pure PVC polymers than for plasticised PVC-insulated copper wire.

In the case of PVC cables, the HCl yield depends only on mass loss and mass charge of the polymeric fraction of cables. Changes in HCl yields from PVC insulation depend only on the nature of the polymer and its fillers, which are not evenly distributed in the polymer fraction and may act as flame retardants.

HCl is well known as a strongly corrosive compound. The occurrence of copper wire decreases the amount of HCl due to a reaction between copper and HCl and between HCl and inorganic fillers. This phenomenon was previously investigated by Grimes et al. [195]. Thermogravimetry, ion chromatography and gas chromatography tests were used for the investigation. It was found that 'the presence of Cu , CuO and $CuCl_2$ retards the thermal degradation of PVC in air and in nitrogen and decreases the percentages of volatile products produced at both stages of the decomposition. These effects are greatest for PVC- CuO . The presence of copper, CuO or $CuCl_2$ in PVC has a major effect on the nature of the gaseous emissions of the thermal decomposition in air and in nitrogen. The concentrations of total chlorine, aliphatic hydrocarbons, aromatic hydrocarbons, chlorinated hydrocarbons and soot particulates are all affected relative to an equivalent amount of PVC'.

The equivalence ratios for tests at 2 l/min of airflow slightly exceeded the 0.7 value, which directly indicated that well-ventilated flaming conditions (1b) – Tab. 1 were obtained close to the borderline in the well-ventilated and small under-ventilated range. Due to low oxygen concentration as an oxidiser, the decrease of CO_2 (equal to 1.09 g/g) was observed in CO and HC yields; however, it gave much worse results in terms of fire toxicity, which were much higher than for pure PVC and LDPE polymers under the same ventilation and temperature conditions. It was also shown that CO yields for the PVC-containing cable decrease together with decreasing ϕ , which was expected due to oxygen concentration accelerating the thermal decomposition reaction of PVC in the combustion zone.

During the combustion process, most cable samples self-extinguished and then reignited. As a consequence, the non-flaming period may result in increasing concentration of products of incomplete combustion, such as CO and various light HCs. Such behaviour, however, corresponds

well to a real fire situation, particularly to the early stages of fire development.

A significant increase in HC yield could be a consequence of aromatic HC emission obtained by a Diels-Alder reaction type cross-linking, and intramolecular decomposition of the polyene segments, resulting from dehydrochlorination. PVC undergoes many thermal decomposition reactions at high temperatures followed by Diels-Alder cyclization reactions. These reactions are catalysed by transition metals, in this case copper, and their kinetics is temperature dependent, not oxidant. They occur in each test under different ventilation conditions, with the increased ventilation simultaneously reducing the temperature of the reaction zone. In the air atmosphere in the combustion zone, aromatic compounds formed in the Diels-Alder reaction oxidize at a rate directly proportional to the amount of available oxidant, i.e. oxygen from the air. Due to the combustion chemistry, the greater the flow, the greater the availability of the oxidant, but on the other hand, the cooling process of the combustion zone increases with increased flow, up to and including the flame blowing out. Thus, two antagonistic phenomena occur simultaneously. Combustion is an exothermic process and it is generally accepted that the rate of reactions accompanying combustion increases exponentially with increasing temperature according to the Arrhenius equation. Unfortunately, the high rate of reaction and the rapid increase in temperature in the combustion zone make it difficult to fully recognize the processes taking place there.

8.1.7. Concentric barrier

Cables in group V (Tab. 2) differ in one feature only, i.e. the presence (or not) of steel armour or concentric copper conductor. The fire properties of these cables were compared in pairs (cable sample 74 and 75, 77 and 78, 80 and 81, 83 and 84, 85 and 87 and 88 and 89). Pairs of cables Nos. 80, 81, and 87, 85 differ slightly in the type of non-metallic materials used for outer sheaths, beddings and insulations, but have the same construction, i.e. number of copper conductors, cross-sectional area and shape.

For cables which consist of galvanised steel and armour or copper concentric conductors (wires and tape) placed between the outer sheath and bedding (cable samples Nos. 74, 77, 81, 83, 85, and 88) – Tab. 2, much lower heat parameters, such as peakHRR_{av} and THR_{1200s} (Fig. 52), were observed than for similar cables without any armour (cable samples Nos. 75, 78, 80, 84, 87 and 89). In general, the measured values are relatively low except for cable samples No. 80, 85 and 87. High values of

smoke release parameters (Fig. 53) for cable samples Nos. 80, 84, 87 and 89 were obtained, with even six times higher values for cable sample No. 83 than 84. This is mainly due to the nature of the material used for outer sheath formulation and the absence of a barrier against flame penetration in the form of metallic armour.

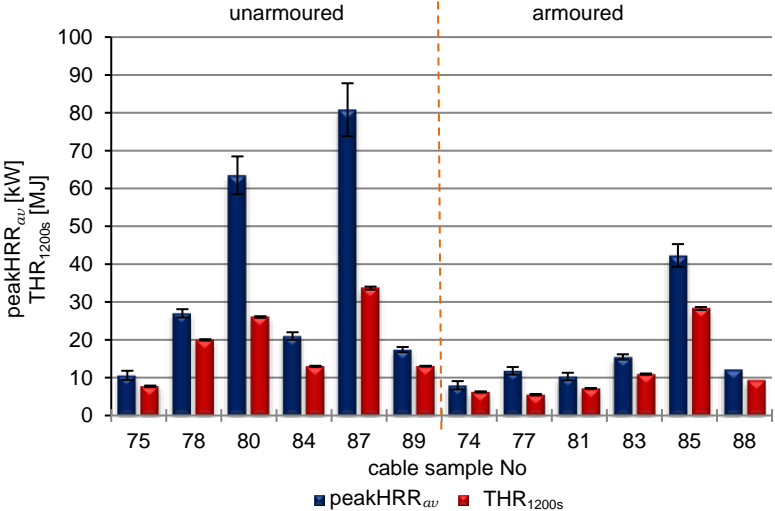

Fig. 52. Heat release results for cables with or without armour and concentric conductor

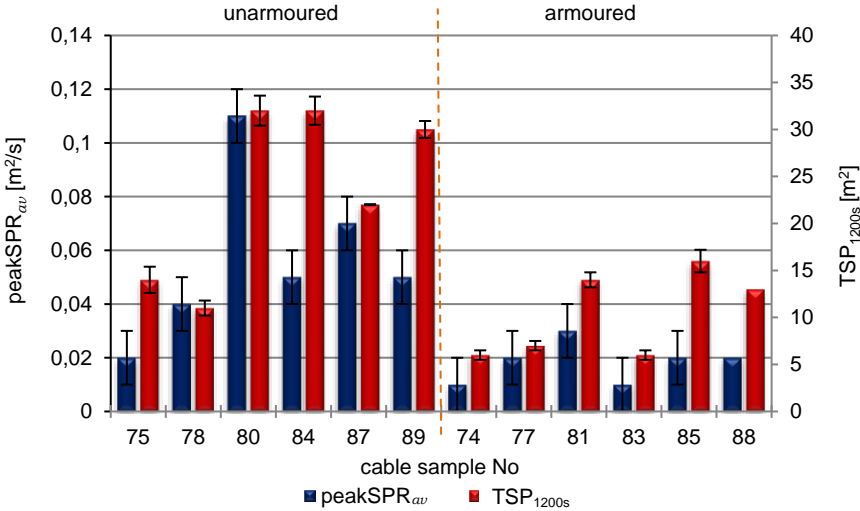

Fig. 53. Smoke production results for cables with or without armour and concentric conductor

Metallic armour forms a natural barrier against fast flame penetration inside the cable, protecting it from FS towards its inner bedding and conductor insulation. This phenomenon causes decreasing heat and smoke parameters for the cables, as well as a decreasing FS parameter, which seems to be associated with HRR (Tab. 4).

The EN 50399 test conditions [4] force the flaming (real-scale) propagation processes and the production of more CO₂ as a product of complete combustion, which results in the higher heat release properties of the cable in the case of cable sample No. 78. This phenomenon may be additionally forced by the flame-retardant process during the thermal treatment of EVA filled with ATH and ZnB compounds. Additional water is formed during the flame-retardant process, which causes self-ignition.

The highest amount of smoke characterised by the TSP_{1200s} parameter (equal to 32 m² for cable sample No. 84) results from the length of damages within a test specimen expressed by the flame spread parameter and equal to 1.12 m. For cable sample No. 78, FS of 1.32 m (Tab. 4) had a similar tendency as cable sample No. 84. The damage covered pieces of cables over their diameter and the flame penetrated inner construction elements of the cables, which then self-extinguished. The area of burned polymeric material decreased the amount of fire effluents as products of complete and incomplete combustion.

Assuming that the metallic armour forms a natural barrier against flame penetration inside the cable, it protects it from internal flame propagation towards its inner bedding and conductor insulation. This phenomenon causes decreasing heat and smoke parameters for the cables.

Cables with and without armour have also been tested within the FIPEC [23] and CEMAC project [199] and their influence on fire properties was presented by Grayson et al. [196]. It is not possible, however, to compare these results with the current investigation, because other constructional-material parameters of the cables were investigated in the previous study. This caused that a direct comparison is not possible.

8.2. Statistical analysis

8.2.1. Large-scale fire tests, cone calorimeter method and fire toxicity tests

The obtained test results are never perfectly accurate, which dictates the calculation of uncertainties. In practice, the sources of systematic and random errors, which can affect measurements are numerous. The determination of uncertainty in large-scale fire tests, i.e. large-scale cable tests,

cone calorimeter and fire toxicity tests, considers the uncertainty caused both by measurement and by the selection of test specimens.

The calculation of the uncertainty of each specimen has been determined using the procedure given in the CEN/TR 16988 technical report. Uncertainty is inversely proportional to accuracy, which consists of trueness and precision. Precision is measurable as the standard deviation, while trueness is expressed numerically by the systematic error or bias [197]. The Type B method of uncertainty calculation was used. It involves the determination of sensitivity coefficient-based uncertainty analysis by an exact differential method of calculation.

The length of damage on the test samples was measured using calibrated measuring tape. The uncertainty of measurements is equal to 1.209 mm.

The repeatability and reproducibility of the EN 50399 test method are shown to be sufficient for the cable test example (Tab. 7).

Table 7. Repeatability and reproducibility of the EN 50399 test method

Fire parameters results		peakHRR _{av} [kW]	THR _{1200s} [MJ]	TSP _{1200s} [m ²]	peakSPR _{av} [m ² /s]
Specimen No.	1	355	125	204	1.06
	2	322	117	228	1.04
	3	327	117	203	0.91
Coefficient of variation [%]		4.3	3.0	6.6	5.5

Each specimen according to EN 50399 consists of a number of cable pieces mounted on the test ladder. Three specimens from the same eight-conductor non-halogenated cable (but other than those taken for the main study) were tested to show the repeatability and reproducibility of the test method. Whole cables were burned and all results are relatively high. A comparison of the results shows good reproducibility of each heat release and smoke production parameter (Tab. 7). Similar results were reported by the authors of the FIPEC [198] and CEMAC projects [199].

The coefficient of variation has been calculated as the ratio of the standard deviation to the mean value of results. It is relatively low for each fire parameter of the three specimens (Tab. 7). The results of the coefficient of variation are much lower than 20%, which is within the uncertainty of the test method. The uncertainties of test results are calculated for each tested specimen.

A single toxicity experiment of specimens in various ventilation conditions has been performed based on the excellent intra-laboratory repeatability and inter-laboratory reproducibility of the ISO 19700 test method by Purser et al. [200], which has been shown previously. Three specimens of four different pure polymers, such as rigid PVC, LDPE, polymethylmethacrylate (PMMA) and polyamide 6.6 (PA6.6) were tested in well-ventilated conditions at a furnace temperature of 650°C and $\phi < 0.75$ (fire stage 2), and in under-ventilated post-flashover conditions at a furnace temperature of 825°C at a previously calculated ventilation condition based on ϕ set to $+2/-0.2$ (fire stage 3b) conditions according to ISO 19706 (Tab. 1) by three independent laboratories. It was found that within laboratory repeatability was less than 10% for most cases (overall average 7.8%), whilst between laboratory reproducibility was somewhat high (overall average equal to 15.8%) [200]. On the basis of these results, one specimen was tested under each ventilation condition in the course of the experiments, which is in accordance with the previously published work of other authors [26, 27].

The results of interlaboratory comparative tests of 16 samples of various building materials on cone calorimeter, carried out in 4 laboratories [201], indicate good repeatability and reproducibility of measurements of fire properties using the cone calorimeter method. There was a small percentage of outliers (14%) and stragglers (13%). Selected material samples ensured evenly distributed results of the measured fire properties. The exception is the ignition time, for which most of the results had very low values with the applied exposure to a large flux of thermal radiation (75 kW/m²). Therefore, the results of the linear regression of ignition time may not reflect the actual precision of the test method in this case.

V. Babrauskas and I. Wetterlund [202] presented a comparison of the results of interlaboratory tests between 7 laboratories on 5 different materials used in the furniture industry (upholstered furniture). The tests were carried out at the intensity of the heat radiation flux of 35 kW/m². The obtained test results indicated that the laboratories were able to perform the tests in a repeatable (r index) and reproducible (R index) manner. The calculated values of r and R were satisfactory and had a value comparable to that obtained during the previous comparative tests (Round Robin) using the cone calorimeter method on samples of building materials and plastics.

8.2.2. Small-scale test methods

The extended uncertainty of specimen mass measurements on the TGA instrument is related to the accuracy of the devices (microscale) used, and has been estimated with the coverage factor k equal to 2.0,

which provides a confidence level of 95%. The calculated extended uncertainty of weight is equal to 0.022 mg.

The uncertainty of temperature measurements with the TGA method is related to the accuracy of the thermocouple, which was calibrated using Ni and ALUMINA® alloy wires. The temperature uncertainty for each test has been calculated with an extension factor k equal to 2.0, which provides a confidence level of 95%, and is equal to 0.66°C. The k factor defines the number of standard deviations used when calculating a confidence level.

In the ATR-FTIR spectroscopy method, the qualitative “fingerprint” spectra are to be treated as test results. Due to the nature of the test, there is no possibility, at the current level of knowledge, to estimate uncertainty in the test results presented.

9. DISCUSSION ON THE CURRENT CABLE PARAMETER χ

As described earlier, in terms of their constructional–material parameters, such as:

- 1) conductor shape,
- 2) type of materials used for their formulation,
- 3) voltage rate,
- 4) concentric barrier occurrence

cables are grouped into so-called “cable families” [1], because cables have more complex fire behaviour than other building products. It is, however, not certain whether the worst fire parameter results for the chosen cables are due to a constructional parameter, such as cable diameter (d_{cable}) or the number of conductors (n) [196].

The fire properties of each cable are expressed as the so-called cable parameter χ (2) [1, 138]. The cable parameter has been invented to predict the monotonical trend of fire parameters obtained during the EN 50399 standard test of cables within the same cable family [1].

According to equation (2), cable parameter χ is directly proportional to the number of conductors (n) and the non-metallic volume of combustible cable components in 1 m of bunched cable (V_{combust}). It is inversely proportional to the square of the diameter of the cable (d_{cable}^2).

The cable parameter has been shown to be more complex than d_{cable} and V_{combust} in the case of selecting cable samples for testing within the identified cable family [196].

Although cable fire performance can be qualitatively well described by constructional parameters, such as number of conductors (n), outer diameter (d_{cable}) and non-metallic volume per metre of ladder according to EN 50399 (V_{combust}), their dependence on fire parameters has been shown to be non-monotonic.

The author’s investigation has shown a simple relationship between the value of cable parameter χ and the number of conductors (n) for cables with a number of conductors less than 19. For non-halogenated cables with a greater number of conductors, increasing values of peak HRR_{av} , $\text{THR}_{1200\text{s}}$, $\text{TSP}_{1200\text{s}}$ and peak SPR_{av} were observed, despite the increasing content of the V_{combust} . This means that not only one construction characteristic may be considered when investigating the fire properties of

cables. Despite the directly proportional relationship of parameter χ to the V_{combust} , the same value of χ may lead to different fire properties of cables.

Spearman's correlation between two variables $\text{THR}_{1200\text{s}}$ and the χ parameter (Fig. 54a), and $\text{TSP}_{1200\text{s}}$ and the χ parameter (Fig. 55a) for cable samples Nos. 33, 36, 42, 44, 45 and 48 (Tab. 2) and the correlation between cable samples, except cable sample No. 33 (Figs 54b and 55b), have been shown. $\text{THR}_{1200\text{s}}$ and $\text{TSP}_{1200\text{s}}$ parameters have been obtained during the test described in EN 50399 and directly depend on the combustible constructional elements of the cables (Fig. 9).

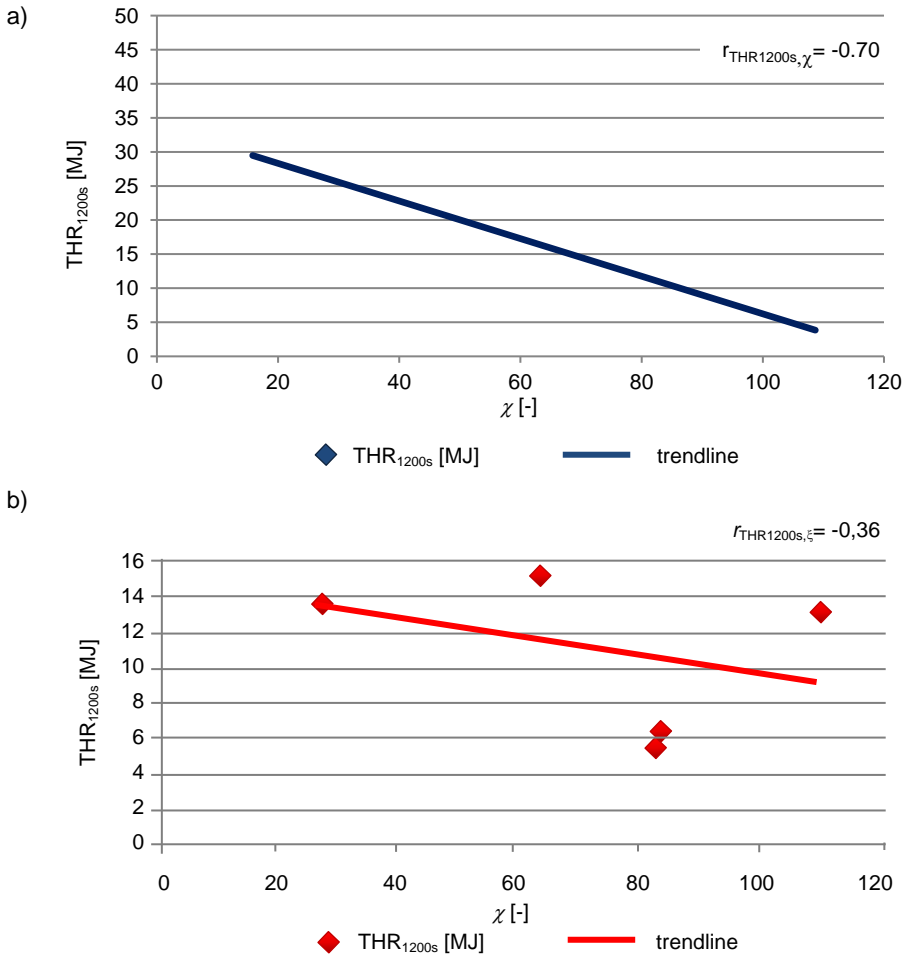

Fig. 54. Correlation between $\text{THR}_{1200\text{s}}$ and χ
 a) 1-, 3-, 14-, 19-, 24- and 30-conductor cables, b) 3-, 14-, 19-, 24- and 30-conductor cables

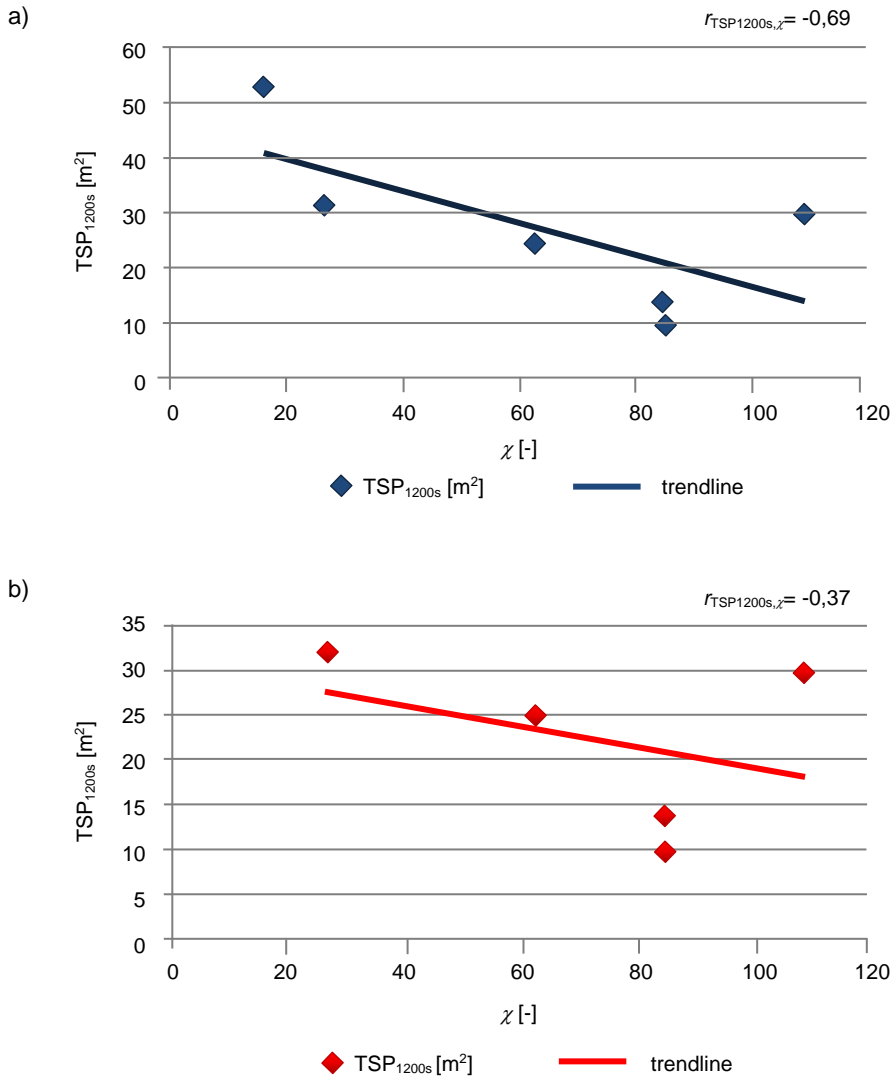

Fig. 55. Correlation between TSP_{1200s} and χ
 a) 1-, 3-, 14-, 19-, 24- and 30-conductor cables, b) 3-, 14-, 19-, 24- and 30-conductor cables

Poor correlation results as a function of cable parameter χ ($r_{THR1200s,\chi} = -0.70$ and $r_{TSP1200s,\chi} = -0.36$) dictated the creation of the new parameter, which would more accurately describe the fire properties of cables differing only in the number of conductors [203].

10. AUTHOR'S CONCEPT OF NEW CABLE PARAMETER

In section 8.1.3, the influence of conductors in the form of metallic barriers against flame penetration inside the cable was discussed, as well as the number of inorganics incorporated in the non-metallic elements of cables, such as outer sheath, bedding and insulations.

The Conservation of Energy Law [204] can be interpreted in relation to combustion, which is the rapid oxidation reaction of a substance called fuel, combined with the release of energy in the form of heat and work. Geometrically, the piece of cable can be considered as a round or elliptical cylinder. During combustion processes, the total energy (heat) released is equal to the difference between heat consumed by the cable and heat released in the combustion zone (Fig. 56). THR is a function of effective combustion surface areas [119].

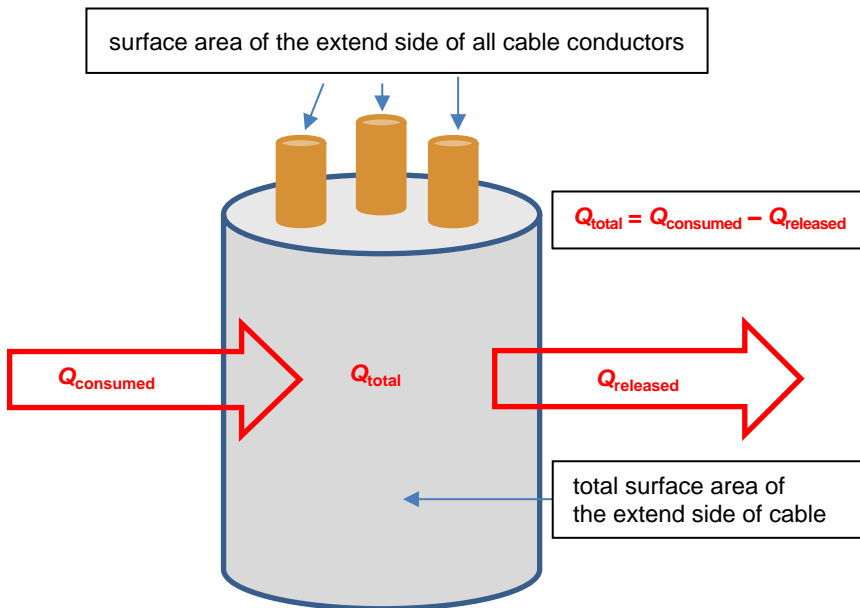

Fig. 56. Idealised schematic of heat transfer within the combustion surface area of cables

Combustion processes are irreversible and quite complex. They can be classified as physical processes among systems where chemical reactions occur. THR depends on the outer active surface area of the cable and the inner active surface area of metallic conductors within the total volume of the cable.

The proposed parameter, which would describe the fire properties of electric cables more precisely, is a volume of effective non-combustible content Ω , which combines all the necessary constructional and material parameters of cables responsible for their fire properties. Ω can be calculated according to equation (14)

$$\Omega = \frac{1}{z} \left(\frac{V_{\text{combust}}}{1 + \omega} \right) \quad (14)$$

where:

- Ω – volume of effective non-combustible content, l/m of cable,
- z – surface ratio [-],
- V_{combust} – non-metallic volume of combustible cable components, l/m bunched cable according to EN 50399 [4],
- ω – non-metallic non-combustible components volume to non-metallic combustible components volume ratio [-].

The surface ratio (z) is related to the heat transfer between the active outer surface of the cable and the surface of metallic conductors inside the cable. Round cables and round conductors are circle-based cylinders with known diameters. It can be defined as the ratio of the surface area of the extended side of all cable conductors and the total surface area of the extended side of the cable (15)

$$z = \frac{\pi d_{\text{met}} h n}{\pi d_{\text{cable}} h} \quad (15)$$

where:

- d_{met} – diameter of conductor [m],
- n – number of conductors [-],
- d_{cable} – diameter of cable [m],
- h – unit length of cable [m].

The non-metallic non-combustible components volume to non-metallic combustible components volume ratio (ω) can be obtained from the TGA of each separate cable component (outer sheaths, beddings and insulations) as a sum of the ratios of mass of residue to mass loss of each component. The air atmosphere in the TGA was chosen because under the

conditions of a real fire, at the initial stages of its development, there is good ventilation and unlimited availability of the oxidant from the air, therefore the TGA analysis in the air atmosphere is a more accurate approximation of the actual processes taking place in the fire. The calculations of each component of equation (14) for six cables are given in Tab. 8. The properties of cables are given in Tab. 2 and the absolute mass loss (Δm), which represents the total mass of non-metallic combustible components of cables, is given in Tab. 8 (chapter 7.2.3).

Table 8. Calculation of Ω parameter

Cable sample No.	n [-]	d_{met} [$m \times 10^{-3}$]	d_{cable} [$m \times 10^{-3}$]	$V_{combust}$ [l/m cable]	χ [-]	ω [-]	Z [-]	Ω [l/m cable]
33	1	1.38	6.7	0.032	15.8	1.54	0.206	0.061
36	3	1.38	13.6	0.126	26.4	1.24	0.304	0.185
42	14	1.38	22.4	0.315	62.5	1.03	0.863	0.180
44	19	1.38	24.7	0.387	83.3	1.02	1.062	0.181
45	24	1.38	27	0.492	84.9	0.89	1.227	0.213
48	30	1.38	30.5	0.562	108.7	1.23	1.357	0.186

As mentioned above, the THR_{1200s} and TSP_{1200s} parameters are strongly dependent on combustible material content. Spearman's correlations for both fire parameters as a function of the Ω parameter show a similar tendency to those obtained for the χ parameter, and increase together with the number of cables for testing (Figs 57 and 58).

The values of linear correlation coefficient r for THR_{1200s} and TSP_{1200s} observed are close to -1 ($r_{THR_{1200s}, \Omega} = -0.97$ and $r_{TSP_{1200s}, \Omega} = -0.88$) – Figs 57a) and 58a), which demonstrates that there is a (negative) linear relationship between them and the volume of effective non-combustible content Ω , namely the number of cables, metallic flame barriers (conductor barriers) and combustible non-metallic components of cables. The high correlation factors, much higher than for cable parameter χ (Tab. 9) show that smoke production and heat release depend significantly on mass loss of the cable sample, in terms of combustible non-metallic content, which is in line with our explanation of physical phenomena.

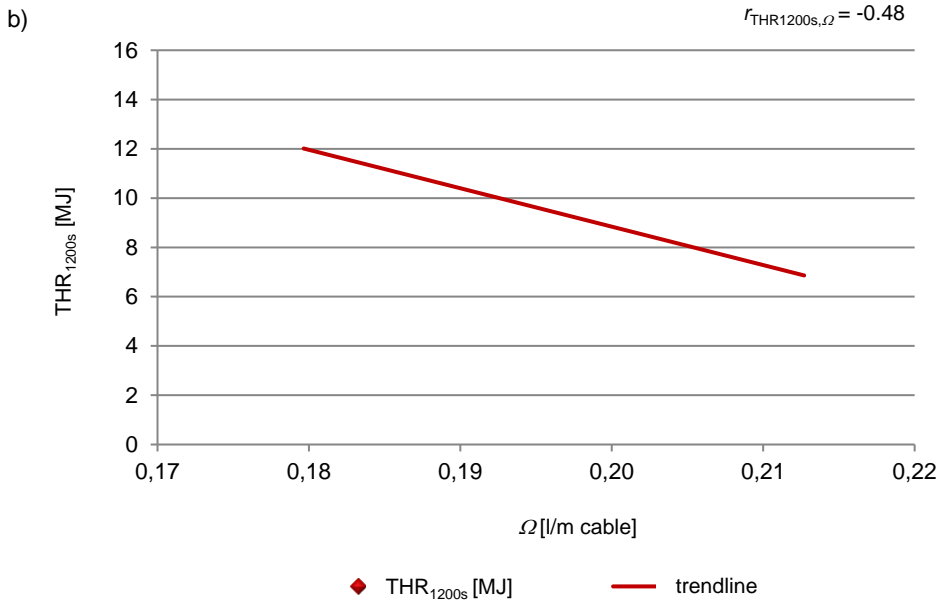
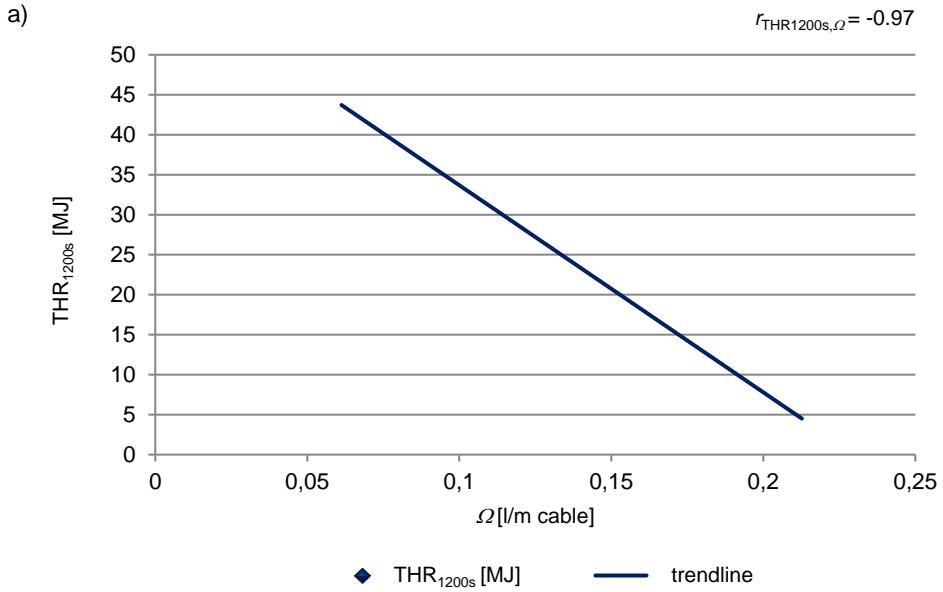

Fig. 57. Correlation between THR_{1200s} and Ω
 a) 1-, 3-, 14-, 19-, 24- and 30-conductor cables, b) 3-, 14-, 19-, 24- and 30-conductor cables

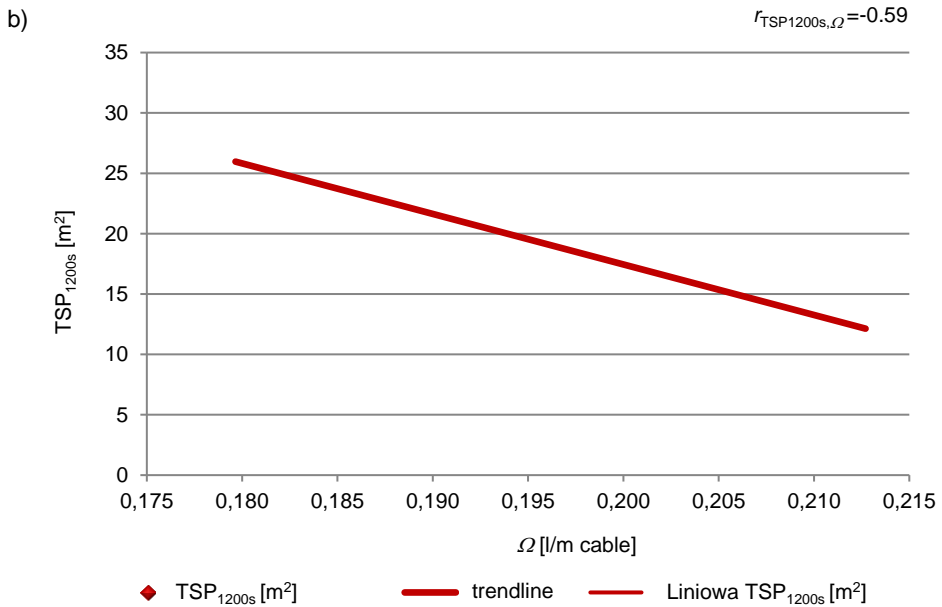
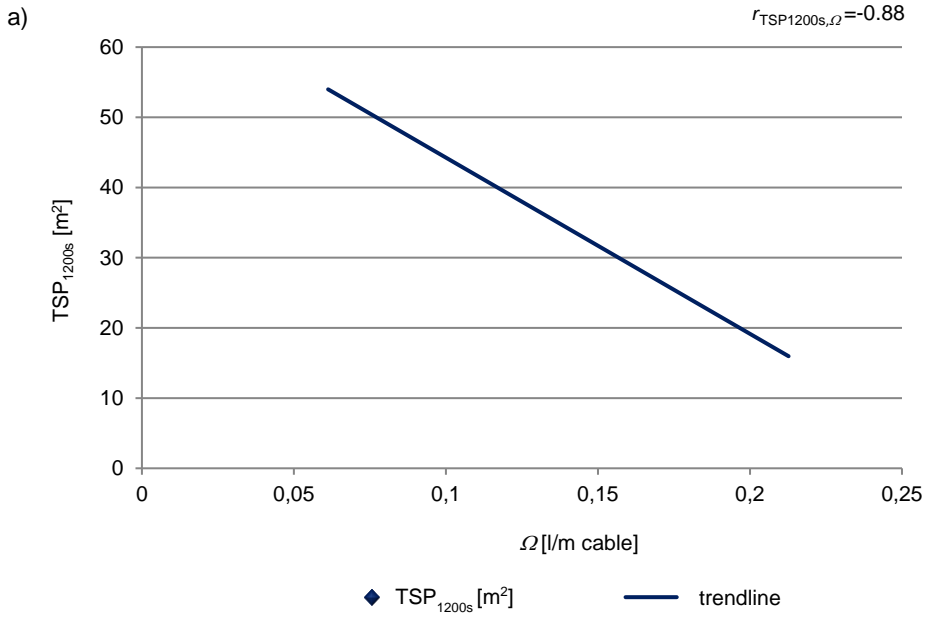

Fig. 58. Correlation between TSP_{1200s} and Ω
 a) 1-, 3-, 14-, 19-, 24- and 30-conductor cables, b) 3-, 14-, 19-, 24- and 30-conductor cables

Table 9. Comparison of r values for cable parameters χ and Ω

	peakHRR _{av} [kW]	THR _{1200s} [MJ]	TSP _{1200s} [m ²]	peakSPR _{av} [m ² /s]	FS [m]
$r_{x,\Omega}$	-0.98	-0.97	-0.88	-0.97	-0.97
$r_{x,\chi}$	-0.69	-0.70	-0.69	-0.68	-0.71

It is shown (Tab. 9) that the lowest value of the Ω parameter was obtained for cables without any bedding in the construction, consisting of one copper conductor, thus a low amount of combustible non-metallic content. In the case of multi-conductor cables, the lowest value of the Ω parameter has been determined for the three-conductor cable, as expected. The highest value of the Ω parameter for cables which consist of 24 conductors rather than 30 conductors, however, highlighted the strong relationship of the combustible non-metallic volume of cables, which is much stronger than the number of cable conductors.

Similar calculations are proposed for the Ω parameter for non-circular cables, which are treated as cylindroids. The difference between non-circular and round cables is due to their cross-section and only factor z needs to be derived from a formula. The rest of the components of equation (14) remain unchanged. Factor z depends on the active surface (area of the side) that undergoes thermal impact and needs to be calculated using equation (16)

$$z = \frac{\pi d_{met} h n}{S_{cable}} \quad (16)$$

where:

d_{met} – diameter of conductor [m],

n – number of conductors [-],

h – unit length of cable [m],

S_{cable} – area of the side of cable [m²].

The area of the side of the cable should be calculated using approximate equation (17):

$$S_{cable} = \pi h (1.5(a+b) - \sqrt{ab}) \quad (17)$$

where:

h – unit length of cable [m],

a – major axis [m],

b – minor axis [m].

Conversely, conductors in cables with sector-shaped conductors should be treated as prisms with the base of an isosceles triangle, whereas the cable is always circular. This takes place in the case of 3-, 4- and 5-conductor cables (classes 1 and 2), differing depending on the number of conductors in the cable:

- 1) 3-conductor cable: internal angle in isosceles triangle equal to 120° ,
- 2) 4-conductor cable: internal angle in isosceles triangle equal to 90° ,
- 3) 5-conductor cable: internal angle in isosceles triangle equal to 72° .

An example cross-section of a cable with sector wires is shown in Fig. 11b.

On this basis, the proposed surface ratio z should be determined as the ratio of the surface areas of the side of the respective prisms, and calculated using equation (18)

$$z = \frac{P_{met} n}{\pi d_{cable} h} \quad (18)$$

where:

- n – number of conductors [-],
- d_{cable} – diameter of cable [m],
- h – unit length of cable [m],
- P_{met} – area of the side of conductor [m].

The area of the side of the single conductor might be determined assuming that the base of the prism is an isosceles triangle (equation 19)

$$P_{met} = (2a + b)h \quad (19)$$

where:

- h – unit length of cable [m],
- a, b – sides of the triangles [m].

The proposed new cable parameter Ω is a more precise reflection of the fire performance of electric cables than the existing cable parameter χ . The new parameter may apply to every construction of electric cables.

11. APPLICATION OF QUINTIERE'S THEORY

Beginning in the 1970s, a number of independent research centres dealt independently with issues related to the ignitability of materials from external fire sources, burning rates and the influence of external radiation on the susceptibility to combustion [205, 206, 207, 208, 209]. Professor James Quintiere from the University of Maryland, USA has formulated a specific theory related to these issues.

The thermodynamic properties of liquid materials, such as EHC, heat of gasification and burning rate per unit area, are measurable and physically true, which is not the case for solid materials, especially charring materials or those including non-combustible fillers, which do not melt [133] (forming a liquid phase) and evaporate.

Quintiere's theory derived from the observation that 'many materials will not burn in air without the addition of radiant heat flux' [133] and is based on splitting solid materials into two groups: thermally thin and thermally thick [210]. Thermally thin objects have no spatial, internal temperature gradient. Their thickness (d) is less than the thermal penetration depth. The simple theory of thermally thin ignition applies to materials of thickness (d) insulated on one side, or a material of thickness ($2d$) heated symmetrically. Examples of thermally thin solids are a single sheet of paper, fabrics and plastic films [134].

Thermally thick solids, where the ignition of a solid might be approximated by a semi-infinite medium, are much more complicated. Backface boundary conditions might be negligible in that case. The theory suggests that the time of ignition is always directly proportional to incident radiant heat flux (20) [134]. The thermally thick material always has a temperature distribution that is not influenced by the backface effect [133]

$$t_{ig} = \frac{\pi}{4} k \rho c \left(\frac{T_{ig} - T_0}{q_e} \right)^2 \quad (20)$$

where:

- t_{ig} – time to ignition [s],
- k – thermal conductivity [W/(m×K)],
- ρ – density of the material [kg/m³],
- c – heat capacity [kJ/(kg×K)],

- $k\rho c$ – thermal inertia factor [$\text{kW}^2/(\text{m}^4 \times \text{K}^2 \times \text{s})$],
- T_{ig} – ignition temperature (or temperature to ignition) [$^{\circ}\text{C}$],
- T_0 – ambient temperature [$^{\circ}\text{C}$],
- \dot{q}_e'' – external incident heat flux at the surface [kW/m^2].

Electric cables can be considered as composite materials, whose properties vary during the fire test. The fire properties of cables depend on the order of components, which are burned. This type of materials of unknown composition, however, pose difficulties for the determination of thermal inertia factor $k\rho c$, which characterises the thermal properties of materials responsible for ignitability and flame spread.

The theory of the electric cable can be experimentally proven by graphical analysis. For this purpose, a couple of tests were carried out using the cone calorimeter method (described in section 5.2.3) [168] with horizontally configured specimens of a size of 100 mm \times 100 mm. Each specimen (Fig. 59a) consisted of eight pieces of PVC non-circular power cable with dimensions of 3.8 \times 8.5 mm (small axis \times major axis) were tightly packed in the required stainless-steel holder frame, with a ceramic wool fibre blanket of low density (65 kg/m³) as backing material, according to the standard. 100 mm lengths of cables were arranged tangentially to each other in the sample holder, with the major axis in the direction of the cone, so the sample thickness was 3.8 mm.

The surface of the cable specimens was covered by a steel grid in order to minimise swelling of the cable (supporting the expanded surface of PVC). The ends of the cable pieces were protected by aluminium foil to avoid additional inflammation.

In order to predict the results of the large geometrical scale fire tests, the following parameters have been highlighted:

- heat release parameter (HRP), defined as the heat of combustion to the heat of gasification ratio, is determined as a slope of peakHRR as a function of radiant heat flux,

- thermal response parameter (TRP) – equation (21), which is directly proportional to time to ignition, may be assessed by setting the inverse slope of $(1/t_{ig})^{-1/2}$

$$\text{TRP} = \sqrt{\left(\frac{\pi}{4} k\rho c\right)} (T_{ig} - T_0) \quad (21)$$

- critical heat flux (CHF) is the minimum heat flux needed to ignition, and is proportional to ignition temperature (T_{ig}),

- available energy parameter (AEP), defined as the total energy (heat) released during burning per area, is set by the calculation of the integral of HRR per area [211].

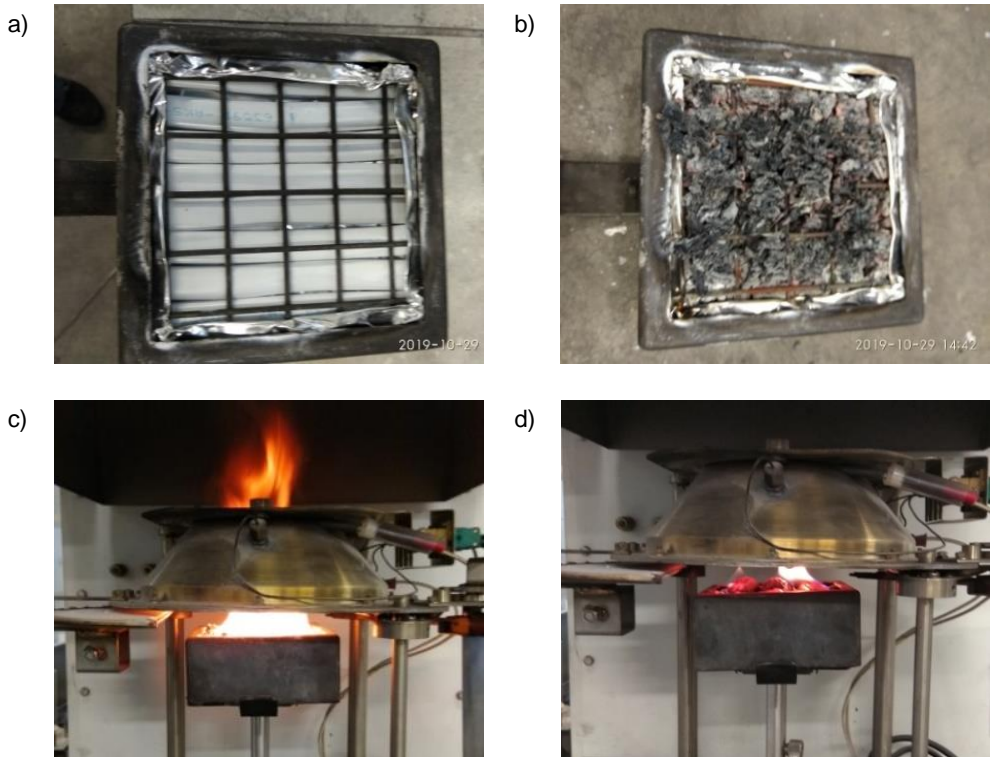

Fig. 59. PVC-insulated and sheathed non-circular cable placed in holder a) before the test, b) after the test, c) test after ignition, d) about 600 s of test duration

The original set of four parameters given above has been shown as sufficient for describing all aspects of a material's contribution to fire growth and therefore hazard in a given fire scenarios [136].

During the test of the PVC non-circular power cable, the various parameters related to heat release, time to ignition and smoke production were obtained (Figs 60, 61 and 62) [212]. The linear relationship between the maximum of HRR per unit area (peakHRR_{pua}) and external radiant heat flux (Fig. 60) was shown to be as expected. peakHRR_{pua} increases together with the set cone radiation. An HRP parameter has been obtained as a slope of the trend line and is equal to 3.8.

In the case of external heat flux equal to 10 kW/m^2 , the test specimen was not ignited during 1800 s of test duration. The fire effluents observed and the mass loss of 8% of the total mass of the specimen indicated the presence of pyrolysis. The linear relationship between time inverse $(1/t_{ig})^{-1/2}$ and radiant heat flux for the PVC non-circular power cable is shown in Fig. 61.

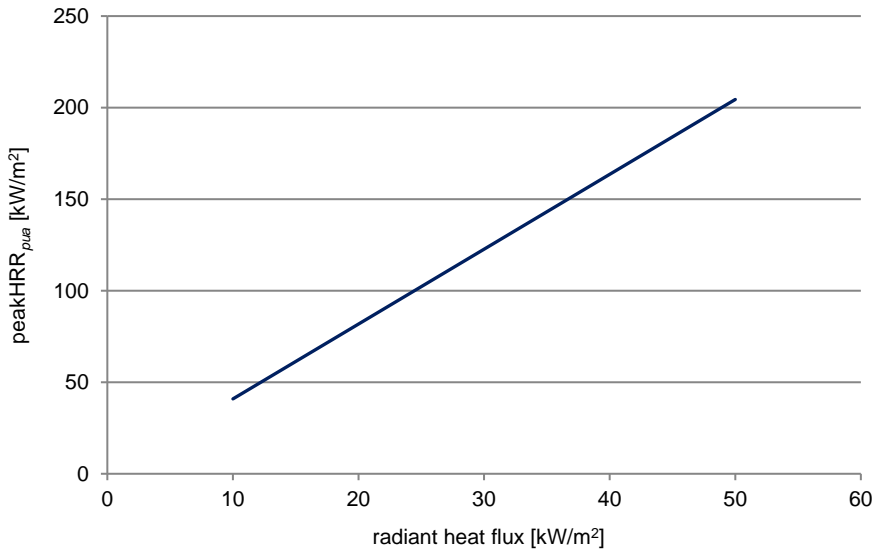

Fig. 60. peakHRR_{pua} as a function of radiant heat flux for PVC non-circular power cable

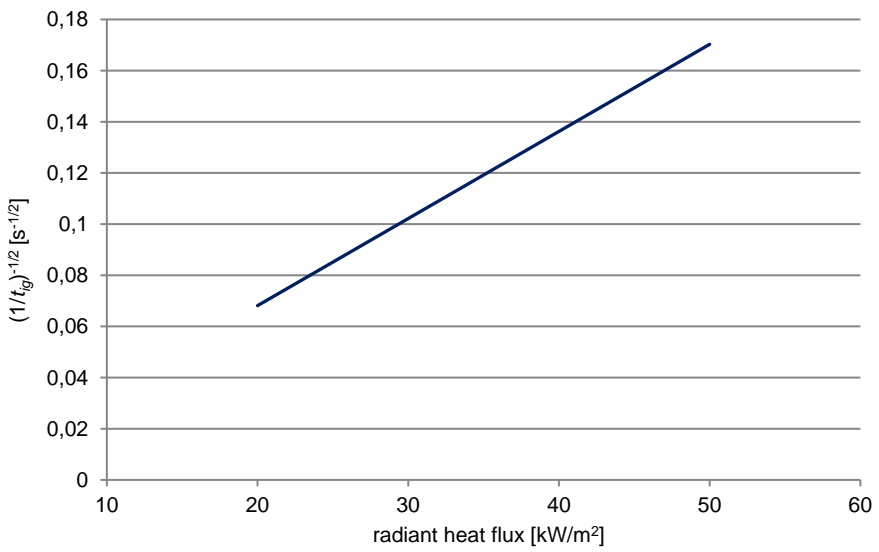

Fig. 61. Relationship between time inverse and radiant heat flux for PVC non-circular power cable

The results (Figs 60 and 61) are very similar to those available in the literature for homogeneous solid materials, such as various wood samples and plastic foams [133, 134, 209, 211] and also for electric cables [213]. This illustrates that Quintiere’s theory applies to the fire modelling of electric cables, provided that the values of coefficients characteristic of the solid materials involved are known.

Smoke release was also taken under consideration. The rate of smoke release (RSR) parameters during the test varies significantly on the external set heat flux (Fig. 62). The highest peak of smoke release has been obtained for 50 kW/m² radiation and the lowest for 10 kW/m², where no ignition occurs and smoke release increases together with increasing heat flux. The time period of smoke release also depends on radiant heat flux and finished with the flameout of the test specimens.

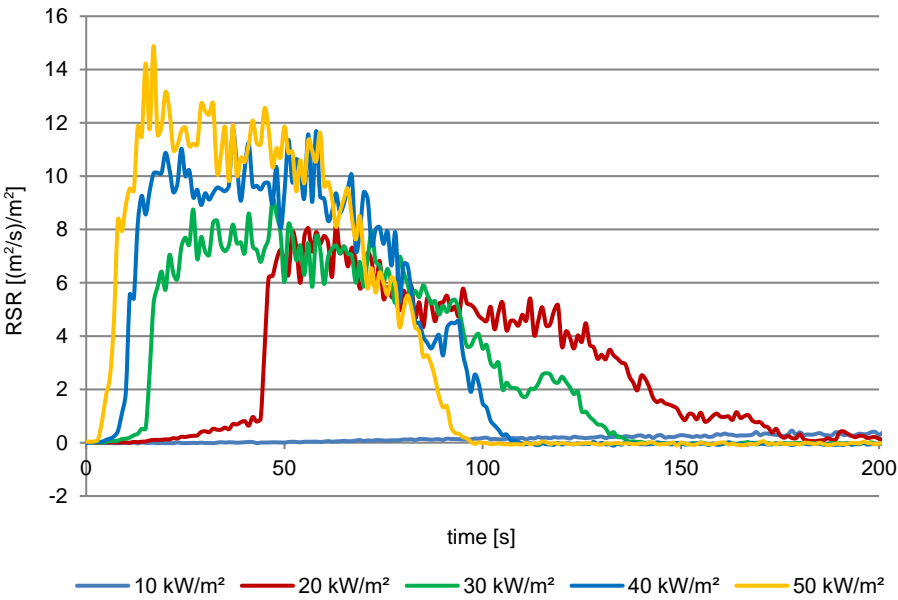

Fig. 62. Smoke release rate as a function time for PVC non-circular power cable tested in cone calorimeter

The application of Quintiere’s theory to material fire tests can significantly reduce the number of tests. It should be highlighted that this approach would allow the results to be expressed in terms of a limited number of parameters, which are, however, impossible to calculate without determining the basic characteristic parameters related to cable flammability, i.e. thermal conductivity, overall density and heat capacity. It

would not be possible to determine the appropriate fire modelling parameters for composite solid materials, where the values of HRP, TRP, CHF, AEP and $k\rho c$ factor are not known.

12. CONCLUSIONS

Certain constructional-material parameters of cables increase the mechanical and electrical properties of cables used in buildings but at the same time contribute to the deterioration of their fire properties.

Flame spread, heat release and smoke generation parameters are significant factors increasing the fire properties of electric cables and, thus, the fire properties of entire buildings.

In the course of the study, it was found that:

1. Factors, such as the shape, number and material used for the formulation of conductors (peakHRR_{av} parameter was three to four times lower for copper than for aluminium cables), and the types of materials from which the non-metallic elements of the cables are made, as well as the presence of armour or concentric conductors decrease the fire parameters of cables, such as heat release, smoke production, fire spread and fire effluent toxicity.
2. The construction of the cable strongly influences its fire behaviour due to the creation of a barrier against flame penetration and the emission of combustion effluents: inside the closed agglomeration of non-combustible metallic conductors and through the intumescent structures formed from inorganic fillers and fire retardants in the outer sheath material during the self-sustained combustion process following the ignition of cables. The heterogeneous distribution of non-combustible inorganic fillers or the different content of fillers and flame retardants within the polymer fraction cause irregular fire behaviour in cables. The presence of bedding in multi-conductor cable constructions results in the decreasing values of combustion parameters (peakHRR_{av}, THR_{1200s}, peakSPR_{av} and TSP_{1200s}), e.g. increases the fire properties of cables (peakHRR_{av} parameter six to seven times lower for multi-conductor than for single-conductor cables).
3. The performed experiments enabled the development of a new concept of Ω parameter, which is a more precise predictive indicator of cable flammability than the standardised cable parameter χ , which inadequately describes the fire properties of electric cables. The construction of electric cables, especially the amount of non-

-metallic combustible materials and conductor metal barriers, prompted the development of a new parameter, which includes both considered characteristics. The proposed author's concept of Ω parameter depends on the volume of effective non-combustible content, and is presented in litres of non-combustible non-metallic components per meter of cable, as χ parameter. It prompted the development of a new concept of Ω parameter, which includes both considered characteristics, thus the scientific problem was solved.

4. It was confirmed that there is good agreement between the cone calorimeter test data expressed by means of Quintiere's theory and the results of real-scale cable fire experiments.
5. LSOH cables generate less heat, smoke and toxic gases than materials based on plasticised PVC. Therefore, they are more suitable for end-use application in terms of the fire behaviour of entire buildings, as opposed to PVC cables (peakHRR_{av} parameter more than 17 times higher for fully halogenated cables), which is a very important finding for the fire properties of buildings.

Further studies are necessary in order to obtain more data allowing better understanding and explanations of the significant influence of electrical installations on flame spread inside a building. PVC cable channels and installation pipes are usually made of combustible polymeric materials and their behaviour during a cable fire needs to be examined. They constitute significant risks to the fire safety of buildings through increasing the ability of fire spread through walls, ceilings and floorings. Simplifying the fire test protocol of cables should be considered further, as an application potential suggested by this study. Finally, this thesis has shown that real-scale fire tests can be replaced by small-scale cone calorimeter applications of Quintiere's theory, which significantly simplifies the analysis of the fire behaviour of cables.

REFERENCES

- [1] CLC/TS 50576:2016 Electric cables – Extended application of test results for reaction to fire
- [2] ISO 13943:2017 Fire Safety – Vocabulary
- [3] EN 50575:2015 Power, control and communication cables – Cables for general applications in construction works subject to reaction to fire requirements
- [4] EN 50399:2011+A1:2016 Common test methods for cables under fire conditions – Heat release and smoke production measurement on cables during flame spread test – Test apparatus, procedures, results
- [5] KACZOREK-CHROBAK K.: Electric cables used in buildings – dependency of fire properties on constructional and material parameters. Doctor of Philosophy Thesis. Instytut Techniki Budowlanej, Warsaw 2020
- [6] CTIF Report 24 World Fire Statistics, 2019
- [7] Statystyki zdarzeń Systemu Wspomagania Decyzji Państwowej Straży Pożarnej (SWD PSP) za rok 2019 (*Event statistics of the State Decision Support System (SWD PSP) for 2019*) [Dostępny w: <https://dane.gov.pl/dataset/1783,statystyki-zdarzen-systemu-wspomagania-decyzji-panstwowej-strazy-pozarnej-swd-ppsp-za-rok-2019> accessed 26.05. 2020 – in Polish]
- [8] EN 1991-1-2:2002 Eurocode 1 Actions on structures – Part 1-2: General actions – Actions on structures exposed to fire
- [9] KOSIOREK M.: Bezpieczeństwo pożarowe budynków (*Fire safety of buildings*). Budownictwo ogólne. Fizyka budowli. Arkady, Warsaw 2005 – in Polish
- [10] Obwieszczenie Ministra Inwestycji i Rozwoju z dnia 8 kwietnia 2019 r. w sprawie ogłoszenia jednolitego tekstu rozporządzenia Ministra Infrastruktury z dnia 12 kwietnia 2002 r. w sprawie warunków technicznych, jakim powinny odpowiadać budynki i ich usytuowanie (Dz. U. z 2019 r., poz. 1065) – *Notice of Ministry of Investment and Development of 8 April 2019 on unified text of Decree of Ministry of Infrastructure on technical requirements for buildings and their location* – in Polish

- [11] PN-ISO 8421-1:1997 Fire protection – Vocabulary – Part 1: General terms and phenomena of fire. Bilingual edition
- [12] TROITZSCH J.: Prescriptive regulations and tests considering the toxicity of fire effluents. [In:] *Fire Toxicity*. Edited by Stec A. A. and Hull T. R. Woodhead Publishing in Materials, Sawston 2010, pp. 562–582
- [13] KACZOREK-CHROBAK K.: Reakcja na ogień kabli bezhalogenowych oraz kabli na bazie PVC (*Reaction to fire of PVC-based halogen-free electric cables*). *Elektro.info* 2015, nr 10, pp. 25–27 – in Polish
- [14] JOURNEAUX T.: Developments in fire performance cables for Energy – Materials design and selection. *IEE Colloquium (Digest)* 1999, Vol. 74, pp. 8–11
- [15] Regulation (EU) No 305/2011 of the European Parliament and of the Council of 9 March 2011 laying down harmonised conditions for the marketing of construction products and repealing (Council Directive 89/106/EEC)
- [16] EN 13501-6:2018 Fire classification of construction products and building elements – Part 6: Classification using data from reaction to fire tests on power, control and communication cables
- [17] EN 13501-1:2018 Fire classification of construction products and building elements – Part 1: Classification using data from reaction to fire tests.
- [18] LYON R. E., SAFRONAVA N, QUINTIERE J. G., STOLIAROV S. I., WALTERS R. N., CROWLEY S.: Material properties and fire test results. *Fire and Materials* 2014, Vol. 38, pp. 264–278 (doi: 10.1002/fam.2179)
- [19] HIRSCHLER M. M.: Poly(vinyl chloride) and its fire properties. *Fire and Materials* 2017, Vol. 41, pp. 993–1006 (doi: 10.1002/fam.2431)
- [20] SARAZIN J., BACHELET P., BOURBIGOT S.: Fire behavior of simulated low voltage intumescent cables with and without electric current. *Journal of Fire Sciences* 2017, Vol. 35(3), pp. 179–194 (doi: 10.1177/0734904117698843, hal-01697376)
- [21] HIRSCHLER M. M.: Hydrogen chloride evolution from the heating of poly(vinyl chloride) compounds. *Fire and Materials* 2005, Vol. 29, pp. 367–382 (doi: 10.1002/fam.893)
- [22] FERNANDEZ-PELLO A. C., HASEGAWA H. K., STAGGS K., LIPSKA-QUINN A. E., ALVARES N. J.: A Study of the Fire Performance of Electrical Cables. *Fire Safety Science*. [In:] *Fire Safety Science – Proceedings of the Third International Symposium, Londyn 2007*, pp. 237–247 [Dostępny w: <https://iafss.org/publications/fss/3/237>]

- [23] GRAYSON S. J., VAN HEES P., GREEN A. M., BREULET H., VERCELLOTTI U.: Assessing the Fire Performance of Electric Cables (FIPEC). *Fire and Materials* 2001, Vol. 25(2), pp. 49–60 (doi: 10.1002/fam.756)
- [24] BARNES M. A., BRIGGS P. J., HIRSCHLER M. M., MATHESON A. F., O'NEILL T. J.: A Comparative Study of the Fire Performance of Halogenated and Non-Halogenated Materials for Cable Applications. Part I. Tests on Materials and Insulated Wires. *Fire and Materials* 1996, Vol. 20, pp. 1–16 [Dostępny w: [https://doi.org/10.1002/\(SICI\)1099-1018\(199601\)20:1<1::AID-FAM553>3.0.CO;2-W](https://doi.org/10.1002/(SICI)1099-1018(199601)20:1<1::AID-FAM553>3.0.CO;2-W)]
- [25] VAN HEES P., AXELSSON J., GREEN A., GRAYSON S.: Mathematical modelling of fire development in cable installations. *Fire and Materials* 2001, Vol. 25, Issue 4, pp. 169–178 (doi: 10.1002/fam.767)
- [26] HULL T. R., STEC A. A., LEBEK K., PRICE D.: Factors Affecting the Combustion Toxicity of Polymeric Materials. *Polymer Degradation and Stability* 2007, Vol. 92(12), pp. 2239–2246 (doi: 10.1016/j.polymdegradstab.2007.03.032)
- [27] HULL T. R., LEBEK K., STEC A. A., PAUL K. T., PRICE D.: Bench-Scale Assessment of Fire Toxicity. [In:] *Proceedings of Advances in the Flame Retardancy of Polymeric Materials: Current perspectives presented at FRPM'05*. Edited by Schartel B., Berlin 2007
- [28] PURSER D. A.: Performance of Fire Retardants in Relation to Toxicity, Toxic Hazard and Risk in Fires. [In:] *Fire Retardant Materials*. Edited by Horrock A. R. and Price D. CRC Press/Woodhead Publishing, Cambridge 2001, pp. 449–499
- [29] HILADO C. J.: *Flammability Handbook for Plastics*. 5th Edition. Technomic Publishing Company Inc., CRC Press, Boca Raton 1998
- [30] ISO TS 19706:2011 Guidelines for assessing the fire threat to people
- [31] STEC A. A., HULL T. R., LEBEK K.: Characterisation of Steady State Tube Furnace (ISO 19700) for Fire Toxicity Assessment. *Polymer Degradation and Stability* 2008, Vol. 93(11), pp. 2058–2065 (doi: 10.1016/j.polymdegradstab.2008.02.020)
- [32] BABRAUSKAS V.: The Generation of CO in Bench-scale Fire Tests and the Prediction for Real-scale Fires. *Fire and Materials* 1995, Vol. 19, pp. 205–213 (doi.org/10.1002/fam.810190503)
- [33] PAULUHN J.: Toxicity of fire effluents. [In:] *Plastics Flammability Handbook*. 3rd Edition. Carl Hanser Verlag GmbH & Co. KG. Edited by Troitzsch J. et. al., Monachium 2004, pp. 629–659
- [34] PÓLKA M., JASKÓŁOWSKI W.: Zagrożenia toksyczne powstałe podczas eksploatacji kabli elektroenergetycznych w warunkach pożarowych (*Toxic hazards arising during the operation of power cables in fire*)

- conditions). XI Sympozjum „Problemy eksploatacji układów izolacyjnych wysokiego napięcia”, Krynica, Poland, Sep 25 – 28 2007 – in Polish
- [35] WELTE U.: Safe cabling system in tunnels under fire. [In:] Proceedings of 3rd International Conference Tunnel Safety and Ventilation, Graz 2006
- [36] LENARTOWICZ R.: Bezpieczeństwo użytkowania instalacji elektrycznych w Polsce (*Safety in using electrical installations in Poland*). *Elektro.info* 2014, nr 3, pp. 64–67 – in Polish
- [37] BOURBIGOT S., SARAZIN J., BACHELET P.: Small scale evaluation and characterization of simulated low voltage cables with and without electrical current. *Fire and Materials* 2015, Vol. 12, pp. 12–22 [Dostępny w: <https://www.proceedings.com/content/028/028174/webtoc.pdf>]
- [38] Wiring rules. *Journal of the Institution of Electrical Engineers* 1907, Vol. 39, Issue 184, pp. 231–266 (doi: 10.1049/jiee-1.1907.0052)
- [39] GENTILE P., MAZZARO M., TURTURICI C.: Fire safety criteria in electrical installations design. [In:] Proceedings of 17th IEEE International Conference on Environment and Electrical Engineering and 1st IEEE Industrial and Commercial Power Systems Europe. EEEIC / I and CPS Europe, Milan, Italy, 2017 (doi: 10.1109/EEEIC.2017.7977876)
- [40] TENAGA S.: Guidelines for Electrical Wiring. Distribution Division, TNB, 2011 [Dostępny w: [http://www.axanaga.com/v2/download//Suruhanjaya Tenaga Guidelines For Electrical Wiring In Residential Buildings.pdf](http://www.axanaga.com/v2/download//Suruhanjaya%20Tenaga%20Guidelines%20For%20Electrical%20Wiring%20In%20Residential%20Buildings.pdf)]
- [41] MCCLUNG L. B., HILL D. J.: Electrical system design techniques to improve electrical safety. [In:] Proceeding of the 2010 IEEE IAS Electrical Safety Workshop. ESW, TN, USA, Memphis 2010 (doi: 10.1109/ESW.2010.6164462)
- [42] BATES B.: Safer electrical installations. *IEE Review* 1998, Vol. 44(3) (doi: 10.1049/ir:19980306)
- [43] BS 7671:2008 Requirements for Electrical Installations. Electrical Safety and the Law. Blackwell Science Ltd, pp. 122–174 (doi: 10.1002/9780470774519.ch10)
- [44] BABRAUSKAS V.: Research on electrical fires: The state of the art. *Fire Safety Science* 2009, Vol. 9, pp. 3–18 (doi: 10.3801/IAFSS.FSS.9-3)
- [45] HUANG X., NAKAMURA Y.: A Review of Fundamental Combustion Phenomena in Wire Fires. *Fire Technology* 2020, Vol. 56, pp. 315–360 (doi: 10.1007/s10694-019-00918-5)

- [46] BARROS J., DIEGO R. I.: A review of measurement and analysis of electric power quality on shipboard power system networks. *Renewable and Sustainable Energy Reviews* 2016, Vol. 62, pp. 665–672 (doi:10.1016/j.rser.2016.05.043)
- [47] FALVO M. C., CAPPARELLA S.: Safety issues in PV systems: Design choices for a secure fault detection and for preventing fire risk. *Case Studies in Fire Safety* 2015, Vol. 3, pp. 1–16 (doi: 10.1016/j.csfs.2014.11.002)
- [48] MANZINI G., GRAMAZIO P., GUASTELLA S., LICOTTI C., BAFFONI G. L.: The fire risk in photovoltaic installations – Checking the PV modules safety in case of fire. *Energy Procedia* 2015, Vol. 81, pp. 665–672 (doi: 10.1016/j.egypro.2015.12.051)
- [49] BACKSTROM R., DINI D.: Firefighter safety and photovoltaic installations research project. [In:] Proceedings of SPIE. The International Society for Optical Engineering, Reliability of Photovoltaic Cells, Modules, Components and Systems V. California, San Diego 2012 (doi: 10.1117/12.965313)
- [50] XIAOYU J., ZHOU X., ZHAO K., HU Y., MU T., NI Y., YANG L.: Experimental study on burning behaviors of photovoltaic panels with different coverings using a cone calorimeter. *Journal of Renewable and Sustainable Energy* 2017, Vol. 9(6), pp. 063502 (doi: 10.1063/1.4990830)
- [51] CHOW C. L., HAN S. S.: Studying Fire Behaviour of Photovoltaic Panels with a Cone Calorimeter. [In:] Proceeding of 14th International Conference and Exhibition on Fire and Materials, San Francisco, USA, Feb 2 – 4 2015, pp. 53–63
- [52] NOVAK C. J., STOLIAROV S. I., KELLER M. R., QUINTIERE J. G.: An analysis of heat flux induced arc formation in a residential electrical cable. *Fire Safety Journal* 2013, Vol. 55, pp. 61–68 (doi: 10.1016/j.firesaf.2012.10.007)
- [53] PLUMECOCQ W., COUTIN M., RIGOLLET M. L.: Characterization of closed doors electrical cabinet fires in compartments. *Fire Safety Journal* 2011, Vol. 46(5), pp. 243–253 (doi: 10.1016/j.firesaf.2011.02.006)
- [54] HUANG L. C., CHANG H. C., CHEN C. C., KUO C. C.: A ZigBee-based monitoring and protection system for building electrical safety. *Energy and Buildings* 2011, Vol. 43(6), pp. 1418–1426 (doi: 10.1016/j.enbuild.2011.02.001)
- [55] KACZOREK-CHROBAK K., SULIK P., PAPIS B. K.: Wymogi dotyczące reakcji na ogień kabli elektroenergetycznych w tunelach (*Reaction*

- to fire of cables in tunnels – requirements). *Technika Transportu Szynowego* 2015, Vol. 22(12), pp. 756–761 – in Polish
- [56] MATSUDA A.: Fire safety simulation of cable fire in nuclear power plant room based on flammability database of cables. [In:] Proceedings of Transactions, SMiRT-23 Manchester, United Kingdom, August 10–14 2015, Division III, Paper ID 514 (Applied Computation Simulation and Animation)
- [57] JANSSENS M. L., TURNER S., TSUCHINO S.: THIEF model evaluation for cables used in nuclear plants in Japan. *Procedia Engineering* 2013, Vol. 62, pp. 829–836 (doi: 10.1016/j.proeng.2013.08.132)
- [58] FANGRAT J.: Combustibility of building products versus fire safety. *Bulletin of the Polish Academy of Sciences. Technical Sciences* 2016, Vol. 64, No. 4, pp. 709–717 (doi: 10.1515/bpasts-2016-0080)
- [59] Rozporządzenie Ministra Transportu i Gospodarki Morskiej z dnia 30 maja 2000 r. w sprawie warunków technicznych, jakim powinny odpowiadać drogowe obiekty inżynierskie i ich usytuowanie (Dz. U. z 2000 r. nr 63, poz. 735 z późniejszymi zmianami) – *Regulation of the Minister of Transport and Maritime Economy of 30 May 2000 on technical conditions to be met by road engineering facilities and their location* – in Polish
- [60] Rozporządzenie Ministra Infrastruktury z dnia 17 czerwca 2011 r. w sprawie warunków technicznych, jakim powinny odpowiadać obiekty budowlane metra i ich usytuowanie (Dz. U. z 2011 r. nr 144, poz. 859) – *Regulation of the Ministry of Infrastructure of 17 June 2011 on the technical conditions to be met by metro building structures and their location* – in Polish
- [61] FANGRAT J., KACZOREK-CHROBAK K., PAPIS B. K.: Fire Behaviour of Electrical Installations in Buildings. *Energies* 2020, Vol. 13(23), p. 6433 (doi: 10.3390/en13236433)
- [62] KACZOREK-CHROBAK K., FANGRAT J., PAPIS B. K.: Evaluation of Electrical Installations in Terms of Fire Safety of Buildings. [In:] Proceedings of 65th International Conference, Krynica, Sep 15–22 2019
- [63] WYBRAŃSKA I., LENARTOWICZ R.: Projektowanie i montaż instalacji oraz urządzeń elektrycznych w podłożu i na podłożu palnym (*Design and assembly of electrical installations and devices in/on a combustible substrates*). ITB Research Project No NE-2/03 3649/5. ITB, Warszawa 2003 (mps) – in Polish
- [64] KACZOREK-CHROBAK K., FANGRAT J.: Influence of constructional-material parameters on the fire properties of electric cables. *Energies* 2019, Vol. 12(23), pp. 4569–4582 (doi: 10.3390/en12234569)

- [65] KACZOREK-CHROBAK K., FANGRAT J.: Constructional-material parameters vs. fire properties of electric cables. [In:] Proceedings of 24th International Symposium on Combustion Processes, Wrocław, Poland, Sep 23–25 2019
- [66] ZAVALETA P., AUDOUIN L.: Cable tray fire tests in a confined and mechanically ventilated facility. *Fire and Materials* 2018, Vol. 42, pp. 28–43 (doi.org/10.1002/fam.2454)
- [67] HUANG X., ZHU H., PENG L., ZHENG Z., ZENG W., BI K., CHENG C., CHOW W.: Burning behavior of cable tray located on a wall with different cable arrangements. *Fire and Materials* 2019, Vol. 43(1), pp. 64–73 (doi.org/10.1002/fam.2669)
- [68] DELICHATSIOS M. A., DELICHATSIOS M. M.: Upward Flame Spread and Critical Conditions for PE/PVC Cables in a Tray Configuration. *Fire Safety Science*. [In:] Proceedings of the 4th International Symposium, Ottawa 1994, pp. 433–444 [Dostępny w: https://www.iafss.org//publications/fss/4/433/view/fss_4-433.pdf]
- [69] SIEMON M., RIESE O., FORELL B., KRÖNUNG D., KLEIN-HESSLING W.: Experimental and numerical analysis of the influence of cable tray arrangements on the resulting mass loss rate and fire spreading. *Fire and Materials* 2019, Vol. 43(3), pp. 497–513 (doi: 10.1002/fam.2689)
- [70] WANG Z., WEI R., OUYANG D., WANG J.: Investigation on thermal stability and flame spread behavior of new and aged fine electrical wires. *Journal of Thermal Analysis and Calorimetry* 2020, Vol. 140, pp. 157–165 (doi: 10.1007/s10973-019-08778-5)
- [71] HUANG X., ZHU H., PENG L., ZHENG Z., ZENG W., BI K., CHENG C., CHOW W.: Thermal Characteristics of Vertically Spreading Cable Fires in Confined Compartments. *Fire Technology* 2019, Vol. 55, pp. 1849–1875 (doi: 10.1007/s10694-019-00833-9)
- [72] COURTY L., GARO J. P.: External heating of electrical cables and autoignition investigation. *Journal of Hazardous Materials* 2017, Vol. 321, pp. 529–538 (doi: 10.1016/j.jhazmat.2016.09.042)
- [73] YANG H., FU Q., CHENG X., YUEN R. K. K., ZHANG H.: Investigation of the flammability of different cables using pyrolysis combustion flow calorimeter. *Procedia Engineering* 2013, Vol. 62, pp. 778–785 (doi.org/10.1016/j.proeng.2013.08.125)
- [74] MARTINKA J., WACHTER I., STEFKO T., RATUCH P., KOBETICOVA H.: New trends in fire testing of electrical cables. [In:] Proceedings of International Multidisciplinary Scientific GeoConference Surveying Geology and Mining Ecology Management. SGEM, Bulgaria, Sofia 2018, Vol. 18(6.4), pp. 479–486 [Dostępny w: <https://www.sgem.org/sgemlib//spip.php?article13608>]

- [75] CARCILLO M., CARO A.-S., SONNIER R., FERRY L., GESTA E., LAGREVE C.: Fire behaviour of electrical cables in cone calorimeter: Influence of cables structure and layout. *Fire Safety Journal* 2018, Vol. 99, pp. 12–21 (doi.org/10.1016/j.firesaf.2018.05.001)
- [76] BRAUN E., SHIELDS J. R., HARRIS R. H.: Flammability characteristics of electrical cables using the cone calorimeter. NIST Report, MD, USA, Gaithersburg 1989. NISTIR 88 4003 [Dostępny w: <https://nvlpubs.nist.gov/nistpubs/Legacy/IR/nistir88-4003.pdf>]
- [77] HIRSCHLER M. M.: Survey of fire testing of electrical cables. *Fire and Materials* 1992, Vol. 16, pp. 107–118 (doi: 10.1002/fam.810160302)
- [78] MARTINKA J., RANTUCH P., ROLINEC M., POKORNY J., BALOG K., KUCERA P., RYBAKOWSKI M., SULOVA J.: A new approach to the assessment of the reduction in visibility caused by fires of electrical cables. *Safety* 2019, Vol. 5(3), art. No 44 (doi: 10.3390/safety5030044)
- [79] YOSHIDA S., ITO K., TAMAMOTO Y., AIDA F., HOSOKAWA E.: Flash and ignition characteristics of flame retardants materials. [In:] Proceedings of International Wire and Cable Symposium. Virginia, Arlington, November 17-19 1989, pp. 318–325 [Dostępny w: <https://apps.dtic.mil/sti/pdfs/ADA189610.pdf>]
- [80] MEINIER R., SONNIER R., ZAVALETA P., SUARD S., FERRY L.: Fire behavior of halogen free flame retardant electrical cables with the cone calorimeter. *Journal of Hazardous Materials* 2017, Vol. 342, pp. 306–316 (doi: 10.1016/j.jhazmat.2017.08.027)
- [81] KIMZEY J. H., DOWNS W. R., ELDRED C. H., NORRIS C. W.: Flammability in Zero-Gravity Environment. NASA Technical Report No R-246. USA, Texas, Houston 1966 (typescript)
- [82] NEUSTEIN R. A., MADER P. P., COLOMBO G. V., RICHARDSON D. E.: The Effect of Atmosphere Selection and Gravity on Burning Rate and Ignition Temperature. McDonnell Douglas Astronautics Co. Report DAC-62431, NASA CR-106652. California, Santa Monica, October 1968
- [83] FRIEDMAN R., SACKSTEDER K. R.: Fire Behaviour and Risk Analysis in Spacecraft. [In:] Proceedings of 1988 Winter Annual Meeting of the American Society of Mechanical Engineers. Chicago, Illinois, Nov. 28 – Dec 3 1988 [Dostępny w: <https://ntrs.nasa.gov/search.jsp?R=19890000740>]
- [84] FRIEDMAN R., OLSON S. L.: Fire Safety Applications for Spacecraft. [In:] Proceedings of Symposium on Aircraft Fire Safety. Portugal, Sintra, May 22–26 1989

- [85] NASA-STD-6001:1998 Flammability, odor, offgassing, and compatibility requirements and test procedures for materials in environments that support combustion
- [86] JOMAAS G., TORERO J. L., EIGENBROD C., NIEHAUS J., OLSON S. L., FERKUL P. V., LEGROS G., FERNANDEZ-PELLO A. C., COWLARD A. J., ROUVREAU S., SMIRNOV N., FUJITA O., T'ÏEN J. S., RUFF G. A., URBAN D. L.: Fire safety in space – beyond flammability testing of small samples. *Acta Astronautica* 2015, Vol. 109, pp. 208–216 (doi: 10.1016/j.actaastro.2014.11.025)
- [87] OLSON S. L., MILLER F. J., JAHANGIRIAN S., WICHMAN I. S.: Flame spread over thin fuels in actual and simulated microgravity conditions. *Combustion and Flame* 2009, Vol. 156(6), pp. 1214–1226 (doi: 10.1016//j.combustflame.2009.01.015)
- [88] LEGROS G., MINSTER O., TÓTH B., FERNANDEZ-PELLO A. C., T'ÏEN J.S., TORERO J.L., COWLARD A. J., EIGENBROD C., SMIRNOV N., FUJITA O., ROUVREAU S., JOMMAS G.: Microgravity Flammability Experiments for Spacecraft Fire Safety. [In:] Proceedings of the 63rd International Astronautical Congress. Italy Mostra d'Oltremare, October 1–5 2012
- [89] RUFF G., URBAN D. L., FERNANDEZ-PELLO A. C., T'ÏEN J., TORERO J. L., LEGROS G., EIGENBROD C., SMIRNOV N., FUJITA O., COWLARD A. J., ROUVREAU S., MINSTER O., TÓTH B., JOMAAS G.: Development of Large-Scale Spacecraft Fire Safety Experiments. [In:] Proceedings of 43rd International Conference on Environmental Systems. Vail, July 14–18 2013 (doi: 10.2514/6.2013-3410)
- [90] OLSON S. L., RUFF G. A., MILLER F. J.: Microgravity Flame Spread in Exploration Atmospheres: Pressure, Oxygen, and Velocity Effects on Opposed and Concurrent Flame Spread. NASA/TM-2008: 215260. USA, California, San Francisco 2008 (doi: 10.4271/2008-01-2055)
- [91] FUJITA O., KYONO T., KIDO Y., ITO H., NAKAMURA Y.: Ignition of electrical wire insulation with short-term excess electric current in microgravity. *Proceedings of the Combustion Institute* 2011, Vol. 33(2), pp. 2617–2623 (doi: 10.1016/j.proci.2010.06.123)
- [92] TAKANO Y., FUJITA O., SHIGETA N., NAKAMURA Y., ITO H.: Ignition limits of short-term overloaded electric wires in microgravity. *Proceedings of the Combustion Institute* 2013, Vol. 34(2), pp. 2665–2673 (doi: 10.1016/j.proci.2012.06.064)
- [93] GALLO E., STÖCHLEIN W., KLACK P., SCHARTEL B.: Assessing the reaction to fire of cables by a new bench-scale method: Development of bench-scale fire test. *Fire and Materials* 2014, Vol. 41(6), pp. 768–778 (doi: 10.1002/fam.2417)

- [94] GIRARDIN B., FONTAINE G., DUQUESNE S., BOURBIGOT S.: Fire test at reduced scale as powerful tool to fasten the development of flame-retarded material: Application to cables. *Journal of Fire Science* 2016, Vol. 34(3), pp. 240–264 (doi: 10.1177/0734904116642618)
- [95] MATALA A., HOSTIKKA S.: Fire modelling of flame retardant electrical cable. [In:] Proceedings for 12th International Fire and Materials Conference, San Francisco, USA, 31 Jan – 2 Feb 2011, pp. 583–596
- [96] MATALA A., HOSTIKKA S.: Pyrolysis modelling of PVC cable materials. *Fire Safety Science* 2011, Vol. 10, pp. 917–930 (doi: 10.3801/IAFSS.FSS.10-917)
- [97] MI H., LIU Y., JIAO Z., WANG W., WANG Q.: A numerical study on the optimization of ventilation mode during emergency of cable fire in utility tunnel. *Tunneling and Underground Space Technology* 2020, Vol. 100, pp. 2411–2502 (doi: 10.1016/j.tust.2020.103403)
- [98] MUN S.-Y., HWANG C.-H.: Experimental and Numerical Studies on Major Pyrolysis Properties of Flame Retardant PVC Cables Composed of Multiple Materials. *Materials* 2020, Vol. 13, pp. 1712–1726 (doi:10.3390/ma13071712)
- [99] HUANG X., BI K., XIAO J., PENG L., ZHU H., ZHENG Z.: A Method Evaluating Fire Hazard of Multiple-Layer Cable Tray and its Validation. [In:] Proceedings of the 25th International Conference on Nuclear Engineering ICONE25, Shanghai, China, July 2–6 2017
- [100] ZAVALETA P., HANOUZET R., BEJI T.: Improved Assessment of Fire Spread over Horizontal Cable Trays Supported by Video Fire Analysis. *Fire Technology* 2018, Vol. 55(5), pp. 233–255 (doi: 10.1007/s10694-018-0788-x)
- [101] BEJI T., MERCI B.: Numerical simulation of a full-scale cable tray fire using small-scale test data. *Fire and Materials* 2018, Vol. 43(2), pp. 486–496 (doi: 10.1002/fam.2687)
- [102] YAN E., SUN Y.: Study on the Distribution of Fire Temperature Field of L-type Cable Corridor through Numerical Simulation. *Procedia Engineering* 2018, Vol. 211, pp. 861–870 (doi.org/10.1016/j.pro-eng.2017.12.085)
- [103] MURAKAMI K., TRABER D. L.: Pathophysiological Basis of Smoke Inhalation Injury. *News Physiology Science* 2003, Vol. 18, pp. 125–129 (doi.org/10.1152/nips.01427.2002)
- [104] GANN R. G., BABRAUSKAS V., GRAYSON S. J., MARSH N. D.: Hazards of combustion products: Toxicity, opacity, corrosivity, and heat release: The experts' views on capability and issues. *Fire and Materials* 2011, Vol. 35, pp. 115–127 (doi: 10.1002/fam.1043)

- [105] GANN R. G., BABRAUSKAS V., PEACOCK R. D., HALL J. R.: Fire Conditions for Smoke Toxicity Measurement. *Fire and Materials* 1994, Vol. 18, pp. 193–199 (doi.org/10.1002/fam.810180306)
- [106] HIRSCHLER M. M.: Fire Safety, Smoke Toxicity and Acidity. [In:] Proceedings of Flame Retardants 2004, Interscience Communications, UK, London, February 14–15 2006, pp. 47–58
- [107] MATTHEW E., WARDEN G., DEDMAN J.: A Murine Model of Smoke Inhalation. *AJP Lung Cellular and Molecular Physiology* 2001, Vol. 280(4), pp. 716–723 (doi: 10.1152/ajplung.2001.280.4.L716)
- [108] WANG Z., WANG J., RICHTER H., HOWARD J. B., CARLSON J., LEVENDIS Y. A.: Comparative Study on Polycyclic Aromatic Hydrocarbons, Light Hydrocarbons, Carbon Monoxide and Particulate Emissions from the Combustion of Polyethylene, Polystyrene and Poly(vinyl chloride). *Energy & Fuels* 2003, Vol. 17(4), pp. 999–1013 (doi: 10.1021/ef020269z)
- [109] KACZOREK K., STEC A. A., HULL T. R.: Effect of Temperature and Ventilation Condition on the Combustion Efficiency of Halogenated and Aromatic Fuels. [In:] Proceedings of 4th FireSeat Symposium on Fire Safety Engineering in the UK, Nov 2010, pp. 27–35
- [110] KACZOREK K., STEC A. A., HULL T. R.: Carbon Monoxide Generation in Fires: Effect of Temperature on Halogenated and Aromatic Fuels. *Fire Safety Science* 2011, Vol. 10, pp. 253–263 (doi: 10.3801/IAFFS.FSS.10-253)
- [111] YASUHARA A., HIROYASU I.: Combustion Products of Poly(vinyl chloride). *Journal of Environmental Chemistry* 1991, Vol. 1(3), pp. 525–528 (doi.org/10.5985/jec.1.525)
- [112] YATES T.: Study to evaluate the need to regulate within the Framework of Regulation (EU) 305/2011 on the toxicity of smoke produced by construction products in fires. European Commission Final Report. October 2017
- [113] PURSER D. A.: Combustion Toxicity. [In:] SFPE Handbook of Fire-Protection Engineering. 5th Edition. Springer, 2016 (7 Nov. 2015), pp. 2207–2307
- [114] STEC A. A., HULL T. R.: Fire Toxicity. Woodhead Publishing, Sawston 2010
- [115] ALARIE Y.: Toxicity of Fire Smoke. *Critical Reviews in Toxicology* 2002, Vol. 32(4), pp. 259–289 (doi.org/10.1080/20024091064246)
- [116] BEITEL J., BEYLER C. L., MCKENNA L. A., WILLIAMS F. W.: Overview of Smoke Toxicity Testing and Regulations. Navy Technology Center For Safety And Survivability, Washington DC 1998

- [117] EN 60695-4:2008 Fire hazard testing – Part 4: Terminology concerning fire tests for electrotechnical products
- [118] LENARTOWICZ R., FANGRAT J.: Instalacje zasilające urządzenia bezpieczeństwa pożarowego. T. 1: Układy połączeń i urządzenia zasilające (*Electrical installations supply fire safety equipment. Vol. 1: Schemes of connections and power supply devices*). ITB, Warszawa 2016 – in Polish
- [119] KONECKI M.: Wpływ szybkości wydzielania ciepła i emisji dymu na rozwój pożaru w układzie pomieszczeń (*Effect of heat release rate and smoke emissions on fire development in room layout*). SGSP, Warszawa 2007 – in Polish
- [120] PURSER D., MCALLISTER J. L.: Assessment of Hazard to Occupants from Smoke, Toxic Gases, and Heat. [In:] SFPE Handbook of Fire Protection Engineering. 5th Edition. Springer, 2016 (7 Nov. 2015), pp. 662–704
- [121] ISO 19700:2016 Controlled equivalence ratio method for the determination of hazardous components of fire effluents
- [122] WÓJCICKI S.: Silniki pulsacyjne strumieniowe raketowe (*Pulsation rocket jet engines*). Wydawnictwo Ministerstwa Obrony Narodowej, Warszawa 1962, pp. 113–141 – in Polish
- [123] KACZOREK K.: Bench-Scale Fire Toxicity Measurements of Polymers and Cables. Master of Philosophy thesis, University of Central Lancashire, Preston, Lancashire 2009
- [124] ZHU H. M., JIANG X. G., YAN J. H., CHI Y., CEN K. F.: TG-FTIR analysis of PVC thermal degradation and HCl removal. *Journal of Analytical and Applied Pyrolysis* 2007, Vol. 82(1), pp. 1–9 (doi: 10.1016/j.jaap.2007.11.011)
- [125] NCNEILL I. C., MEMETEA L.: Pyrolysis products of poly(vinyl chloride), dioctyl phthalate and their mixture. *Polymer Degradation and Stability* 1994, Vol. 43(1), pp. 9–25 (doi: 10.1016/0141-3910(94)90221-6)
- [126] WANG Z., WEI R. C., WANG X. H., HE J. J., WANG J.: Pyrolysis and Combustion of Polyvinyl Chloride (PVC) Sheath for New and Aged Cables via Thermogravimetric Analysis-Fourier Transform Infrared (TG-FTIR) and Calorimeter. *Materials* 1997, Vol. 11(10), pp. 1997–2011 (doi: 10.3390/ma11101997)
- [127] CHONG N. S., ABDULRAMONI S., PATTERSON D., BROWN H.: Releases of Fire-Derived Contaminants from Polymer Pipes Made of Polyvinyl Chloride. *Toxics* 2019, Vol. 11(4), p. 57 (doi: 10.3390/toxics7040057)
- [128] SZLEZYNGIER W., BRZOZOWSKI Z. K. Tworzywa sztuczne. Środki pomocnicze i specjalne zastosowanie polimerów (*Plastics. Additives*)

- and special applications of polymers*). T. 1. Wydawnictwo Oświatowe FOSZE, Rzeszów 2012, pp. 213–222
- [129] HOUNSHAM I. D., TITOW W. V.: Fillers in PVC. *Proceedings of PVC Technology*. Springer, Dordrecht 1984, pp. 215–254 (doi.org/10.1007/978-94-009-5614-8_8)
- [130] HIRSCHLER M. M.: Fire performance of Poly(Vinyl Chloride). Update and Recent Developments . [In:] *Proceedings of Flame Retardants '98*. Interscience Communications. UK, London, February 3 – 4 1998, pp. 103–123
- [131] YANG L., WANG Y. Y.: Smoke suppressant and flame retardant properties of PVC/ Zinc Hydroxystannate composites. *Renewable and Sustainable Energy II*, PTS 1-4. *Advanced Materials Research* 2012, Vols 512–515, pp. 2804–2807 (doi: 10.4028/www.scientific.net/AMR.512-515.2804)
- [132] NING Y., GUO S. Y.: Flame-retardant and smoke-suppressant properties of zinc borate and aluminium trihydrate-filled rigid PVC. *Journal of Applied Polymer Science* 2000, Vol. 77(14), pp. 3119–3127 (doi.org/10.1002/1097-4628(20000929)77:14)
- [133] QUINTIERE J. G.: A theoretical basis for flammability properties. *Fire and Materials* 2006, Vol. 30, pp. 175–214 (doi.org/10.1002/fam.905)
- [134] QUINTIERE J. G.: *Fundamentals of Fire Phenomena*. John Wiley & Sons Ltd., New Jersey 2006
- [135] QUINTIERE J. G., RANGWALA A. S.: A theory for flame extinction based on flame temperature. *Fire and Materials* 2004, Vol. 28, pp. 387–402 (doi: 10.1002/fam.835)
- [136] QUINTIERE J. G., LIAN D.: Inherent flammability parameters. Room corner test application. *Fire and Materials* 2009, Vol. 33, pp. 377–393 (doi: 10.1002/fam.998)
- [137] WIATR J., LENARTOWICZ R., ORZECZOWSKI M.: *Podstawy projektowania i budowy elektroenergetycznych linii kablowych SN (Basics of design and construction of MV cable lines)*. T. 1. Zeszyty dla Elektryków. Dom Wydawniczy Medium, Warszawa 2009 – in Polish
- [138] KACZOREK-CHROBAK K., FANGRAT J.: Combustible Material Content vs. Fire Properties of Electric Cables. *Energies* 2020, Vol. 13(23), p. 6172 (doi: 10.3390/en13236172)
- [139] KACZOREK-CHROBAK K.: Toksyczne produkty spalania izolacji i powłok kabli elektro-energetycznych (*Toxic combustion products of insulations and outer sheaths of cables*). *Elektro.info* 2015, Vol. 5, pp. 24–27 – in Polish

- [140] KACZOREK-CHROBAK K., FANGRAT J.: Relationship between Non-Metallic Material Content and Fire Properties of Electric Cables. [In:] Proceedings of INTERFLAM'2019 Conference, London, UK, July 1–3 2019
- [141] GROBICKI J., GERMATA M.: Przewody i kable elektroenergetyczne (*Electric wires and cables*). Wydawnictwo WNT, Warszawa 2012 – in Polish
- [142] Portal branżowy AUTOMATYKA B2B (*Industry website AUTOMATYKA B2B*) [Dostępny w: <https://automatykab2b.pl/temat-miesiaca/43297-anatomia-kabla-przemyslowego>, assessed at 26.05.2020] – in Polish
- [143] HANCOCK S. G.: The use of plastics and rubber in electric power cables. [In:] 7th National Conference of the South African Section of the PRI, Johannesburg 1983
- [144] HENDERSON A. M.: Ethylene Vinyl Acetate (EVA) Copolymers: A General Review. *IEEE Electrical Insulation Magazine* 1993, Vol. 9(1), pp. 30–38 (doi: 10.1109/57.249923)
- [145] LOPEZ-CUESTA J.-M., LAOUTID F., LEROY E., GAUDON P., FERRY L.: Chemical and physico-chemical structuration of combustion residues: A strategy for the improvement of reaction to fire. [In:] 17th Conference on Recent Advances in Flame Retardancy of Polymeric Materials, 2006, pp. 56–69
- [146] SANCHEZ-OLIVARES G., SANCHEZ-SOLIS A., MANERO O., PEREZ-CHAVEZ R., JARAMILLO M., ALONGI J., CAROSIO F.: Improving mechanical properties and reaction to fire of EVA/LLDPE blend for cable applications with melamine triazine and bentonite clay. *Materials* 2019, Vol. 12(15), pp. 2393–2408 (doi: 10.3390/ma12152393)
- [147] SZLEZYNGIER W., BRZozowski Z. K.: Tworzywa sztuczne. Chemia, technologia wytwarzania, właściwości, przetwórstwo, zastosowanie (*Plastics. Chemistry. Technology. Properties. Processing. Applications*). Wydawnictwo Oświatowe FOSZE, Rzeszów 2012 – in Polish
- [148] MCCARTHY S.: Environmentally Benign Resins and Additives For Use in the Wire and Cable Industry. The Massachusetts Toxics Use Reduction Institute University of Massachusetts Lowell, Technical Report, 2003
- [149] PICKERING J. J., LOWELL M. E.: Reduced Emissions Cable Jacket. *Wire Journal International* 1987, Vol. 20(10), pp. 68–76
- [150] MOURITZ A. P., GIBSON A. G.: Flame Retardant Composites. [In:] Fire Properties of Polymer Composite Materials. Vol. 143. Springer, Dordrecht 2006, pp. 237–286

- [151] HULL T. R., WITKOWSKI A., HOLLINGBERY L.: Fire retardant action of mineral fillers. *Polymer Degradation and Stability* 2011, Vol. 96(8), pp. 1462–1469 (doi: 10.1016/j.polymdegradstab.2011.05.006)
- [152] AROZIKI A., AZIZ A., ALAUDDIN S. M., SALLEH R. M., SABET M.: Influence of Magnesium Hydroxide/Aluminum Tri-Hydroxide Particle Size on Polymer Flame Retardancy: An Overview. *International Journal of Chemical Engineering and Applications* 2012, Vol. 3(6), pp. 437–440 (doi: 107763/IJCEA.2021.V3.238)
- [153] CAMINO G., SGOBBI R., ZAOPO A., COLOMBIER S., SCENZA C.: Investigation of Flame Retardancy in EVA. *Fire and Materials* 2000, Vol. 24, pp. 85–90 (doi.org/10.1002/1099-1018(200003/04)24:2<85::AID-FAM724>3.0.CO;2-T)
- [154] WEIL E. D.: Fire-Protective and Flame-Retardant Coatings – A State-of-the-Art Review. *Journal of Fire Sciences* 2011, Vol. 29(3), pp. 259–296 (doi.org/10.1177/0734904110395469)
- [155] EVTUSHENKO M., GRIGORIEV A., RUDAKOVA T. A., OZERIN A.: Effect of aluminum hydroxide on the fireproofing properties of ammonium polyphosphate–pentaerythritol-based intumescent coating. *Journal of Coatings Technology and Research* 2019, Vol. 16(8), pp. 1389–1398 (doi: 10.1007/s11998-019-00221-6)
- [156] SAXENA N. K., SHARMA S. K.: Flame Retardant Smoke Suppressant Coatings for PVC Sheathed Electric Cables. *Journal of Scientific & Industrial Research* 2002, Vol. 61(10), pp. 805–809
- [157] JOURNEAUX T.: European developments in the reaction to fire testing of cables. *Wire Journal International* 2010, Vol. 43(4), pp. 66–71
- [158] FÖRSTH M., SJÖSTRÖM J., WICKSTRÖM U., ANDERSSON P., GIRARDIN B.: Characterization of the thermal exposure in the EN 50399 cable test apparatus. [In:] Proceedings of 14th International Conference and Exhibition on Fire and Materials'2015. San Francisco, USA, 2 – 4 February 2015, pp. 23–37
- [159] BITEAU H., STEINHAUS T., SCHEME C., SIMEONI A., MARLAIR G., BAL N. F., TORERO J.: Calculation Methods for the Heat Release Rate of Materials of Unknown Composition. *Fire Safety Science* 2009, Vol. 9, pp. 1165–1176 (doi: 10.3801/IAFSS.FSS.9-1165)
- [160] TN-169 Theory and Operation of NDIR Sensors. Technical Note, RAE Systems, USA, 1995
- [161] LOGANATHAN S., VALAPA R. B., MISHRA R., PUGAZHENTHI G., THOMAS S.: Thermogravimetry Analysis for Characterization of Nanomaterials. *Micro and Nano Technologies* 2017, pp. 67–108 (doi.org/ 10.1016/B978-0-323-46139-9.00004-9)

- [162] VALAPA R., PUGAZHENTHI G., KATIYAR V.: Thermal degradation kinetics of sucrose palmitate reinforced poly(lactic acid) biocomposites. *International Journal of Biological Macromolecules* 2014, Vol. 65, pp. 275–283 (doi.org/10.1016/j.ijbiomac.2014.01.053)
- [163] GIRARDIN B., FONTAINE G., DUQUESNE S., BURBIGOT S., DELINEAU L., FÖRSTH M., HEWITT F., WITKOWSKI A., STEC A. A., HULL T. R.: Small scale tests and numerical modelling of fire performance for electrical cable. [In:] Proceedings of 14th International Conference and Exhibition on Fire and Materials'2015. USA, San Francisco, 2 – 4 February 2015
- [164] MOHAMED M. A., JAAFAR J., ISMAIL A. F., OTHMAN M. H. D., RAHMAN M. A.: Fourier Transform Infrared (FTIR) Spectroscopy. [In:] Membrane Characterization. Elsevier Inc. 2007, pp. 3–29 (doi.org/10.1016/B978-0-444-63776-5.00001-2)
- [165] HAKKARAAINEN T., MIKKOLA E., LAPERRÉ J., GENSOUS F., FARDELL P., LE TALLEC Y., BAIOCCHI C., PAUL K., SIMONSON MCNAMEE M., DELEU C., METCALFE E.: Smoke gas analysis by Fourier transform infrared spectroscopy – Summary of the SAFIR project results. *Fire and Materials* 2000, Vol. 24(2), pp. 101–112 (doi:10.1002/1099-1018(200003/04)24:23.3.CO;2-U)
- [166] PARASKEVAIDI M., MARTIN-HIRSCH P. L., MARTIN F. L.: ATR-FTIR Spectroscopy Tools for Medical Diagnosis and Disease Investigation. [In:] Nanotechnology Characterization Tools for Biosensing and Medical Diagnosis. Edited by C. S. S. R. Kumar, Berlin 2018, pp. 163–211 (doi: 10.1007/978-3-662-56333-5)
- [167] SPEITEL L. C.: Fourier Transform Infrared Analysis of Combustion Gases. *Journal of Fire Science* 2002, Vol. 20, pp. 349–371 (doi: 10.1177/0734904102020005484)
- [168] ISO 5660-1:2015 Reaction-to-fire tests – Heat release, smoke production and mass loss rate – Part 1: Heat release rate (cone calorimeter method) and smoke production rate (dynamic measurement)
- [169] JANSSENS M., PARKER W. J.: Oxygen Consumption Calorimetry. [In:] Heat Release in Fires. Edited by Babrauskas V. and Grayson S. J. Interscience Communications Ltd., Issaquah 1992, pp. 31–59
- [170] HULL T. R., STEC A. A., KACZOREK K.: Fire Effluent Toxicity: Bench-scale Generation of Toxic Products. [In:] Proceedings of the 6th International Seminar on Fire and Explosion Hazards. Leeds, UK, 11 – 16 April 2010, pp. 759–770 (doi: 10.3850/978-981-08-7724-8_11-04)
- [171] PURSER D. A., FARDELL P. J., ROWLEY J., VOLLAM S., BRIDGEMAN B.: An improved tube furnace method for the generation and measu-

- rement of toxic combustion products under a wide range of fire conditions. [In:] Proceedings of the 6th International Conference Flame Retardants '94. Interscience Communications, London, UK, January 1994, pp. 263–274
- [172] JANSSENS M., PARKER W. J.: Oxygen Consumption Calorimetry. [In:] Heat Release in Fires. Edited by Babrauskas V. and Grayson S. J. Elsevier Applied Science, London 1992, pp. 31–59
- [173] PITTS W.M.: Toxic Yield. [In:] Proceedings of Technical Basis for Performance Based Fire Regulations. A Discussion of Capabilities, Needs and Benefits of Fire and Safety Engineering Conference, San Diego 2001
- [174] KAPLAN H. L., GRAND A. F., SWITZER W. G., MITCHELL D. S., ROGERS W. R., HARZELL G. E.: Effects of Combustion Gases on Escape Performance of the Baboon and the Rat. *Journal of Fire Sciences* 1985, Vol. 3, issue 4, pp. 228–244 (doi.org/10.1177/073490418500300401)
- [175] HULL T. R., PAUL K. T.: Bench-Scale Assessment of Combustion Toxicity – A Critical Analysis of Current Protocols. *Fire Safety Journal* 2007, Vol. 42(5), pp. 340–365 (doi:10.1016/j.firesaf.2006.12.006)
- [176] SUNDSTRÖM B., AXELSSON J., VAN HEES P.: A proposal for fire testing and classification of cables for use in Europe. SP Swedish National Testing and Research Institute Report. Sweden, Borås 2003
- [177] LIDE D. R. et al.: CRC Handbook of Chemistry and Physics. 85th Edition. CRC Press Inc., Boca Raton 2004–2005
- [178] HOLLEY C. E. JR., HUBER E. J. Jr.: The Heat of Combustion of Magnesium and Aluminum. Los Alamos Scientific Laboratory, October 1951 (doi.org/10.1021/ja01156a020)
- [179] GUPTA B. L., VARMA M.: Ignition and combustion studies on metalized UDMH-RFNA bipropellant system. *Indian Journal of Engineering & Materials Sciences* 1999, Vol. 6, pp. 13–21 [Dostępný w: <http://nopr.niscair.res.in/bitstream/123456789/21977/1/IJEMS%206%281%29%2013-21.pdf>]
- [180] ABBUD-MADRID A., FIECHTNER G. J., BRANCH M. C., DAILY J. W.: Ignition and Combustion Characteristics of Pure Bulk Metals: Normal-Gravity Test Results. [In:] Proceedings of 32nd Aerospace Sciences Meeting & Exhibit. NV, USA, Reno, 10-13 January 1994
- [181] SHARMA S.K., SHARMA T.P.: The Effect of Flame Retardant Smoke Suppressants on the Char Morphology of Plasticized PVC. *Fire Technology* 1999, Vol. 35, pp. 276–285 (doi.org/10.1023/A:1015440611340)

- [182] KACZOREK-CHROBAK K., FANGRAT J.: Combustion Products Dependence on Ventilation Conditions for PVC-Insulated Electric Wire. [In:] Proceedings of 11th Mediterranean Combustion Symposium, Adeje, Spain, 16–20 June 2019
- [183] CULLIS C. F., HIRSCHLER M. M.: The Combustion of Organic Polymers. Clarendon Press, Oxford University Press, Oxford, New York 1981
- [184] BABRAUSKAS V.: Heat Release Rates. [In:] SFPE Handbook of Fire Protection Engineering. 5th Edition, Springer, 2016 (7 Nov. 2015), pp. 799–903
- [185] KACZOREK-CHROBAK K., FANGRAT J.: PVC-based copper electric wires under various fire conditions: Toxicity of fire effluents. *Materials* 2020, Vol. 13(5), pp. 1111–1123 (doi: 10.3390/ma13051111)
- [186] STEC A. A., HULL T. R.: Yields and Effects from Common Materials under Different Fire Conditions. [In:] Proceedings of the 6th International Seminar on Fire and Explosion Hazards. United Kingdom, Leeds, 11–16 April 2010, pp. 782–791
- [187] STEC A. A., HULL T. R., LEBEK K., PURSER J. A., PURSER D. A.: The effect of temperature and ventilation condition on the toxic product yields from burning polymers. *Fire and Material* 2007, Vol. 32(1), pp. 49–60 (doi.org/10.1002/fam.955)
- [188] HIRSCHLER M. M.: Chemical Aspects of Thermal Decomposition of Polymeric Materials. [In:] Fire Retardancy of Polymeric Materials. Edited by Grand A. F. and Wilkie C. A. Marcel Dekker, New York 2000, pp. 27–79
- [189] CHIVAS C., BERTRAND J.-P., MALVAUX C., MARLAIR G., TACK K.: Smoke toxicity from combustion products based on polymers containing flame retardant additives. [In:] The flame retardants Conference 2006. Londres, February 2006. Interscience communications. London, UK, pp. 59–69
- [190] MOURITZ A. P., GIBSON A. G.: Health Hazard of Composites in Fire. [In:] Fire Properties of Polymer Composite Materials. Vol. 143. Springer, Netherlands, Dordrecht 2006, pp. 359–384
- [191] BABRAUSKAS V., GANN R. G., LEVIN B. C., PAABO M., HARRIS R. H., PEACOCK R. D., YUSA S.: A methodology for obtaining and using toxic potency data for fire hazard analysis. *Fire Safety Journal* 1998, Vol. 31(4), pp. 345–358 (doi.org/10.1016/S0379-7112(98)00013-7)
- [192] ISO 13344:1996 Determination of the lethal toxic potency of fire effluents
- [193] GANN R. G., BRYNER N. P.: Combustion products and their effects on life safety. [In:] Fire Protection Handbook. 20th Edition. Na-

- tional Fire Protection Association, 2008, pp. 6–27 [Dostępny w: https://tsapps.nist.gov/publication/get_pdf.cfm?pub_id=900093]
- [194] SCHNIPPER A., SMITH-HANSEN L., THOMSEN S. E.: Reduced Combustion Efficiency of Chlorinated Compounds, Resulting In Higher Yields of Carbon Monoxide. *Fire and Materials* 1995, Vol. 1, pp. 61–64 (doi.org/10.1002/fam.810190203)
- [195] GRIMES S. M., LATEEF H., JAFARI A. J., MEHTA L.: Studies of the effects of copper, copper(II) oxide and copper(II) chloride on the thermal degradation of poly(vinyl chloride). *Polymer Degradation and Stability* 2006, Vol. 91, pp 3274–3280 (doi: 10.1016/j.poly-mdegradstab.2006.06.010)
- [196] SUNDSTRÖM B., FÖRSTH M., JOHANSSON P., GRAYSON S., JOURNEAUX T.: Prediction of Fire Classification of Cables. Extended Application of Test Data. [In:] Proceedings of 12th International Fire Science & Engineering Conference Interflam’2010. East Midlands Conference Centre, University of Nottingham, UK, July 5–7 2010
- [197] CEN/TR 16988:2016 Estimation of uncertainty in the single burning item test
- [198] GRAYSON S. J., VAN HEES P., VERCELLOTTI U., BREULET H., GREEN A. M.: Fire Performance of Electric Cables – new test methods and measurement techniques (FIPEC). Final Report of European Commission. United Kingdom, London 2010
- [199] JOURNEAUX T., SUNDSTRÖM B., JOHANSSON P., FÖRSTH M., GRAYSON S. J., GREGORY S., KUMAR S., BREULET H., MESSA S., LEHRER R., KOBILSEK M., LEPPERT H.-D., MABBOTT N.: CEMAC – CE-Marking of cables. 2010, SP Rapport NV-2010:27
- [200] PURSER J. A., PURSER D., STEC A. A., MOFFAT C., HULL T. R., SU J. Z., BIJLOOS M., BLOMQVIST P.: Repeatability and reproducibility of the ISO/TS 19700 steady state tube furnace. *Fire Safety Journal* 2013, Vol. 55, pp. 22–34 (doi.org/10.1016/j.firesaf.2012.10.002)
- [201] URBAS J.: BDMC interlaboratory cone calorimeter test programme. *Fire and Materials* 2002, Vol. 26, pp. 29–35 (doi.org/10.1002/fam.782)
- [202] BABRAUSKAS V., WETTERLUND I.: Testing of Furniture Composites in the Cone Calorimeter: A New Specimen Preparation Method and Round Robin Results. *Fire Safety Journal* 1998, Vol. 30, issue 2, pp. 179–194 (doi.org/10.1016/S0379-7112(97)00038-6)
- [203] KACZOREK-CHROBAK K., FANGRAT J.: Electric Cable Construction Parameter and Its Potential to Foresee the Cable Fire Properties. *Materials* 2023, Vol. 16, issue 4, pp. 1689–1699 (doi: 10.3390/ma16041689)

- [204] ATKINS P. W.: *Chemia fizyczna (Physical Chemistry)*. PWN, Warszawa 2001 – in Polish
- [205] MACEK A.: *Flammability Limits: Thermodynamics and Kinetics*. NBSIR, American Society of Mechanical Engineers, 76-1076. National Bureau of Standards, Gaithersburg, MD 1976
- [206] WILLIAMS F. A.: A review of flame extinction. *Fire Safety Journal* 1981, Vol. 3, pp. 163–175 (doi.org/10.1016/0379-7112(81)90041-2)
- [207] TEWARSON A., PION R.F.: Flammability of plastics-1, burning intensity. *Combustion and Flame* 1976, Vol. 26, pp. 85–103 (doi.org/10.1016/0010-2180(76)90059-6)
- [208] JANSSENS M. L.: *Fundamental Thermophysical Characteristics of Wood and their Enclosure Fire Growth*. NFPA, Washington, USA, DPhil Dissertation at University of Gent, Belgium 1991
- [209] FANGRAT J., HASEMI Y., YOSHIDA M., HIRATA T.: Surface temperature at ignition of wooden based slabs. *Fire Safety Journal* 1996, Vol. 27(3), pp. 249–259 (doi.org/10.1016/S0379-7112(96)00046-X)
- [210] MOURITZ A. P., GIBSON A. G.: *Fire Reaction Properties of Composites*. [In:] *Fire Properties of Polymer Composite Materials*. Vol. 143. Springer, Netherlands, Dordrecht 2006, pp. 59–101
- [211] QUINTIERE J. G.: How to Engineer a Material Fire Test. [In:] *Proceedings of 11th Mediterranean Combustion Symposium*. Spain, Adeje, 16–20 June 2019
- [212] KACZOREK-CHROBAK K., FANGRAT J., PAPIS B. K.: Calorimetric Behaviour of Electric Cables. *Energies* 2021, Vol. 14(4), pp. 1007–1022 (doi: 10.3390/en14041007)
- [213] GANDHI P., PRZYBYLA L., GRAYSON S. J.: *Electric Cables Applications*. [In:] *Heat Release in Fires*. Edited by Babrauskas V. and Grayson S. J. Elsevier Applied Science, London 1992, pp. 545–563

BUILDING RESEARCH INSTITUTE (ITB)

The basic aim of research and development works carried out at the ITB, from the very beginning of its activity (1945), was to ensure the quality of the Polish building industry and to protect the interests of users of the construction works. The research and development works carried out by the Institute for the purposes of construction embrace a wide scope of issues related to fundamental requirements of building law that should be met by building facilities, in particular the following:

- safety of structures • fire safety of building objects • safety in use • sustainable construction • safety of electric installations • rationalization of energy and water use in buildings • protection against noise and vibrations and the impact of vibrations on humans and buildings • environment (including the impact of materials on health and sanitary indoor conditions) • interaction between the environment, the use of buildings and construction
- durability of civil engineering works (including protection against moisture as well as chemical and biological corrosion) • foundation soil • use of installation systems • maintenance of building components (including fire-protection systems and those related to evacuation of people and construction fittings).

As a result of the works carried out, the Institute develops:

- the bases of technical and functional requirements for buildings and building products,
- methods for calculation and designing of building elements,
- test methods and assessment criteria for construction works, their elements and building products,
- technical bases for the building policy of the State.

Besides two locations in Warsaw, the ITB has three remote branches. The Silesian Branch in Katowice deals with construction upon mining exploitation areas and with testing of joint elements. The Wielkopolska Branch in Poznań is concerned with research and approval activities related to the construction fittings, metal-work and finishing and auxiliary products, including building burglary protection. The Mazovian Branch in Pionki deals with testing durability and tightness of construction products and building components under fire condition.

Address: ul. Filtrowa 1, 00-611 Warsaw, tel/fax: (+48 22) 825 13 03



PhD Eng. Katarzyna Kaczorek-Chrobak

She graduated from the Faculty of Chemistry, Warsaw University of Technology (2006) and the Centre for Research of Fire and Hazard, School of Forensic and Investigative Sciences, University of Central Lancashire (2009). She obtained her doctorate in engineering and technical sciences from the Building Research Institute in 2020. Since 2012, she has been working in the Fire Research Department of the Building Research Institute, having taken up the position of assistant professor in 2021. She is involved in testing the fire properties of building materials, but her main speciality is assessing the fire properties of cables and electrical installations and the release of toxic combustion products.

Author and co-author of publications in national and international scientific journals, including *Energies*, *Materials*, *Fire Technology* and reviewer of articles in *Fire Technology* and *Fire Safety Journal*. Co-author of the guidelines *Selection of Electric Cables for Application in Buildings with Consideration to the Reaction to Fire Requirements* (Building Research Institute, Warsaw 2022), addressed to manufacturers, designers, architects and building experts.

She uses her professional experience in national and international standardisation works, being an active member of Technical Committee 53 for Cables and Wires (PKN) and the European Sector Group SG22 for Cables and Wires (CEN/CENELEC). In 2022, she received the award of the Minister of Economic Development and Technology in the doctoral dissertation category for 2021. The dissertation was also recognised by the Scientific Council of the Building Research Institute and in the Paweł Buraczewski competition organised by the Polish Combustion Institute.